



# PUBLIC BUILDING COMMISSION of Chicago

**Brandon Johnson**

Mayor

**Ray Giderof**

Executive Director



# HOUSEKEEPING ITEMS

## While we wait...

### Please **MUTE** your computers and/or cellphones

- Press \*6 to unmute (if asked to speak)

### Please **CHANGE** your screen name

- Use 'Your Name (Company Name (or Initials))'

**EXAMPLE: James Borkman (PBC)**

### Please **ADD** your name to Chat

- Use 'Your Name|Company Name (or Initials)'

**EXAMPLE: James Borkman (PBC)**

### Please **WAIT** for Q&A to ask questions

- Q&A session will be at the end of each meeting
- Feel free to use the 'Chat' feature





**Chicago Department of Transportation  
Works Progress Administration  
Street Reconstruction  
(West 112<sup>th</sup> Street & South Loomis Street)**

**C1617**

**Pre-Bid and Technical  
Review Meeting  
December 30, 2024 at 10:00am**

# AGENDA

Introductions

---

Procurement Details

---

Compliance

---

Technical Review

---

Q&A



# Introductions

# INTRO

PBC

---

CDOT & Partners

---

General Contractors

---

Sub-Contractors/Suppliers

---



# Procurement Details

## PROJECT OVERVIEW

### Project Locations

- West 112th Street from South Fairfield Avenue to South Rockwell Street, Chicago, IL
- South Loomis Street from West 121st Street to West 120th Street, Chicago, IL



## PROJECT OVERVIEW

### General Scope of Work:

- earth excavation
- portland cement concrete base course
- hot-mix asphalt surface course
- sewer main, water main and drainage structures
- concrete curb and gutter
- concrete sidewalks, tactile/detectable warning surface system for curb ramps
- concrete driveways and alleys
- roadway lighting
- thermoplastic pavement marking
- signs
- topsoil, sodding, and tree removal and planting

Contractor will be required to prepare a Phasing and Logistics Plan for review and approval by CDOT and PBC, prior to the mobilization and commencement of any Work.

# Procurement Details

## PROJECT OVERVIEW

### Time of Completion

#### E. Time of Completion

Substantial Completion must be achieved no later than October 31, 2025. Schedule Milestones must be completed as follows:

Milestone Descriptions	Milestone Dates
<b>Schedule Milestone #1: Permitting + Mobilization + Site Control + Submittal Preparation</b> <ul style="list-style-type: none"><li>Pre-Construction, Permitting, Submittals, and Materials and Equipment Procurement.</li></ul> (Work may not commence sooner than February 11, 2025)	3/31/2025
<b>Substantial Completion</b> <ul style="list-style-type: none"><li>Street Re-Construction and Associated Work</li></ul> (Work may not commence sooner than April 1, 2025)	10/31/2025
<b>Schedule Milestone #2: New Landscaping</b> (Work may not commence sooner than October 1, 2025)	11/30/2025

### Liquidated Damages

- **\$1,000.00 per day** - For failure to achieve Substantial Completion
- **\$500.00 per day** - For failure to achieve milestone date(s)

# Procurement Details

## AVAILABILITY OF DOCUMENTS

### PBC Current Opportunities Page

<https://pbcchicago.com/opportunities/cdotwpa112thandloomis/>

### Online Planroom

<https://www.alohaprintgroup.com/planroomc1617>

### Printer Contact Information

Aloha Document Services, Inc.

dba Aloha Print Group

141 West Jackson Boulevard, Suite A100A

Chicago, IL 60604

Contact Name: Virginia (Ginger) Peak

Telephone Number: (312) 542-1300

E-Mail: [orders@alohaprintgroup.com](mailto:orders@alohaprintgroup.com)

#### BOOK 1

- Introduction
- General Project Overview
- Submission Requirements

##### HIGHLIGHTS

- Bid Form
- MBE/WBE/EEO Goals
- Community Area Map

#### BOOK 2

- Standard Terms and Conditions for Contracts

#### BOOK 3

- Technical Specifications

+ CONSTRUCTION  
DRAWINGS

# Procurement Details

## AVAILABILITY OF DOCUMENTS

### Assist Agencies

<https://www.pbcchicago.com/doing-business/assist-agencies/>



**PUBLIC BUILDING COMMISSION OF CHICAGO'S ASSIST AGENCIES**

Assist Agencies are comprised of Chamber of Commerce and Not-for-Profit agencies that represent the interests of small, minority- and/or women-owned businesses. If your agency would like to be added to the PBC's Assist Agencies list, please send an email to [patricia.montenegro@cityofchicago.org](mailto:patricia.montenegro@cityofchicago.org).

<b>African American Contractors Association</b> PO Box #19670 Chicago, IL 60619 Omar Shareef 312-915-5960 aacanafassoc@gmail.com www.aacanaf.org	<b>Black Contractors United</b> 155 North Michigan Avenue Suite 300 Chicago, IL 60601 Shynetta Dockery 773-617-5672 bcu@blackcontractorsunited.com blackcontractorsunited.com	<b>CANDO Corporation</b> 1633 S Michigan Ave Chicago, IL 60615 LaVerne Hall (312) 488-9338 LHall@candocorp.net
<b>Chatham Business Association: Small Business Development, Inc.</b> 800 E 78th St Chicago, IL 60619 Melinda Kelly (773) 994-5006 melindakelly@cbaworks.org cbaworks.org	<b>Chicago Cook Workforce Partnership</b> 69 W Washington Street Suite 2860 Chicago, IL 60602 Marissa Lewis mlewis@chicookworks.org (312) 603-0200 chicookworks.org	<b>Chicago Minority Supplier Development Council</b> 216 W Jackson Boulevard Suite 600 Chicago, IL 60606 Debra Jennings-Johnson (312) 755-8880 info@ChicagoM SDC.org chicagomsdc.org
<b>Chicago Urban League</b> 4510 S Michigan Ave, 3rd Floor Chicago, IL 60653 Kelly Evans (773) 451-3547 kevans@chiul.org chiul.org	<b>Chicago Women in Trades</b> 2444 W 16th St Chicago, IL 60608 Jayne Vellinga (312) 942-1444 jvellinga@cwit2.org chicagowomenintradest2.org	<b>ConstructConnect</b> 3825 Edwards Road, #800 Cincinnati, OH 45209 Amanda Beyer (513) 458-5837, Extension 5108336 amanda.beyer@constructconnect.com ConstructConnect.com
<b>Construction Business Development Center at Prairie State College</b> 202 S Halsted St Chicago Heights, IL 60411 Cathy Svetanoff (708) 709-3568 csvetanoff@prainestate.edu prainestate.edu	<b>Federation of Women Contractors</b> 4210 W Irving Park Rd Chicago, IL 60641 Jaemie Neely (312) 360-1122 info@fwcchicago.com fwcchicago.com	<b>HIRE360 Chicago</b> 2301 S Lake Shore Drive Lakeside Center, Chicago, IL 60616 Deborah Whitaker (312) 575-2500 dwhitaker@hire360chicago.com bids@hire360chicago.com
<b>Hispanic American Construction Industry Association</b> 650 W Lake St, #415 Chicago, IL 60661 Ivette Trevino (312) 575-0389 itrevino@haciaworks.org haciaworks.org	<b>Illinois Black Chamber of Commerce</b> 411 Hamilton Blvd, #1404 Peoria, IL 61602 Larry Ivory & Kenyatta Fisher (309) 740-4430 larryivory@illinoisblackchamber.org, kfisher@ibcc.org illinoisblackchamber.org	<b>Rainbow/PUSH Coalition</b> 930 E 50th St Chicago, IL 60615 John Mitchell (773) 256-2766 jmitchel@rainbowpush.org rainbowpush.org
<b>South Shore Chamber, Inc.</b> 1750 E 71st St Chicago, IL 60649 Tonya Trice (773) 955-9508 ttrice@southshorechamberinc.org southshorechamberinc.org		<b>U.S. Minority Contractors Association</b> 1250 Grove Ave, #200 Barrington, IL 60010 Larry Bullock (847) 852-5010 larry.bullock@usminoritycontractors.org usminoritycontractors.org
<b>Women's Business Development Center</b> 8 S Michigan Ave, #400 Chicago, IL 60603 Donna Beasley (312) 853-3477 dbeasley@wbdc.org wbdc.org		<b>Women Construction Owners &amp; Executives</b> 308 Circle Ave Forest Park, IL 60130 Mary Kay Monaghan (708) 366-1250 mkm@mkmservices.com wcoesa.org

## TECH REVIEW MEETING

### Date/Time

December 30, 2024 at 10:30 a.m.

(Immediately following this meeting)

## SITE VISIT

None has been scheduled.

### Notwithstanding

- Failure of the Bidders to become familiar with the Project shall not relieve or alter the Bidder's responsibility for completing the Work as required by the Contract Documents.

# Procurement Details

## REQUEST FOR INFORMATION (RFI'S)

### Sole Point of Contact

James Borkman, Contract Officer

[james.borkman@cityofchicago.org](mailto:james.borkman@cityofchicago.org)

### Deadline

Current: December 31, 2024 by 4:00 p.m.

### Addenda

None issued to date

# Procurement Details

## BID DUE DATE/TIME

### Due Date/Time

Thursday, January 9, 2025 at 11:00 a.m.

*(Subject to Change via Addendum)*

### Virtual Meeting Details

**NOTE:** The Bid Opening will be streamed **LIVE** and will be **RECORDED** and **AVAILABLE** on our website for viewing on PBC's Home Page [www.pbcchicago.com](http://www.pbcchicago.com) and on the Current Opportunity page for this project found here: <https://www.pbcchicago.com/?p=120670>

## BID SUBMISSION REQUIREMENTS

### Electronic Submission

- One complete copy of bid document
  - Original Signatures (**blue ink**) or Digital Signature
  - Include Bid Bond
  - Include Master Bid Form (Master Bid Tab, ALL Schedule of Prices (2), Award Criteria sheet) in **EXCEL and PDF** format separately within email
- NOTE: The pdf documents should be searchable PDF form and not a scanned copy (signature and other like pages may be scanned).
- Email to: [james.borkman@cityofchicago.org](mailto:james.borkman@cityofchicago.org) **AND** [pbc-procurement@cityofchicago.org](mailto:pbc-procurement@cityofchicago.org)

### If Hardcopy Submission Needed

- *Bidders who are unable to submit their bids electronically may request instruction for submitting a “hard copy” of their bid in writing to the Director of Procurement: James Borkman at: [james.borkman@cityofchiago.org](mailto:james.borkman@cityofchiago.org)*



# Procurement Details

## PRE-AWARD MEETING

### Date/Time

Monday, January 13, 2025 at 10:30 a.m. (Virtual)

(Subject to Change via Addendum)

## NOTICE OF AWARD

### Anticipated Schedule

- Anticipated release of the Notice of Award (NOA) is **January 2025** following the PBC Board of Commissioners Meeting
- Successful General Contractor will be required to provide compliant Certificate of Insurance and Payment and Performance Bond within 7 days of NOA issuance



# Book 1 & 2 Highlights

# Highlights

## Budget, Staffing, and Additional Requirements

- Estimated Construction Budget (Book 1, Page 4) - \$4,000,000 - \$4,200,000
- Mandatory Project Staffing (Book 1, Page 5)
- Scheduling Software Requirements (Book 1, Page 6)
- Liquidated Damages (Book 1, Page 6)
- Prevailing Wage Rates (Book 1, Page 7 and Page 44)

# Highlights

## Joint Venture Opportunities

- Schedule B - Joint Venture Affidavit
- (Book 1, Page 29)
  - ❖ JV Agreement
  - ❖ Certification Letter

### SCHEDULE B - Joint Venture Affidavit (1 of 3)

*This form is not required if all joint venturers are MBE/Non-MBE or WBE/Non-WBE firms. In such case, however, a written joint venture agreement among the MBE/Non-MBE or WBE/Non-WBE firms should be submitted. Each MBE/WBE joint venturer must also attach a copy of their current certification letter.*

A. Name of joint venture \_\_\_\_\_

B. Address of joint venture \_\_\_\_\_  
\_\_\_\_\_

C. Phone number of joint venture \_\_\_\_\_

D. Identify the firms that comprise the joint venture

\_\_\_\_\_  
\_\_\_\_\_

1. Describe the role(s) of the MBE/WBE firm(s) in the joint venture. (Note that a "clearly defined portion of work" must here be shown as under the responsibility of the MBE/WBE firm.)

\_\_\_\_\_  
\_\_\_\_\_  
\_\_\_\_\_

2. Describe very briefly the experience and business qualifications of each non-MBE/WBE joint venturer.

\_\_\_\_\_  
\_\_\_\_\_  
\_\_\_\_\_

E. Nature of joint venture's business

\_\_\_\_\_  
\_\_\_\_\_

F. Provide a copy of the joint venture agreement.

G. Ownership: What percentage of the joint venture is claimed to be owned by MBE/WBE? \_\_\_\_\_ %

H. Specify as to:

1. Profit and loss sharing \_\_\_\_\_ %

2. Capital contributions, including equipment \_\_\_\_\_ %

3. Other applicable ownership interests, including ownership options or other agreements which restrict ownership or control.

\_\_\_\_\_

# Highlights

## THE BID FORM

PROJECT NAME: Chicago Department of Transportation Works Progress Administration ("WPA") Street Reconstruction

LOCATION: West 112th Street & South Loomis Street

CONTRACT NO: C1617

PROJECT NO(S): 22306 and 22307

FIRM NAME:

### BID FORM

Bidders MUST use the Excel File available to bidders from the Aloha Print Group Planroom: <https://www.alohaprintgroup.com/planroomc1617> or the PBC Website (<https://pbcchicago.com/?p=120670>) to ensure accurate calculations for the Total Base Bid and Total Award Criteria. Please follow instructions on the Bid Form (below) for Electronic Submission.

West 112th St.	LINE	DESCRIPTION	AMOUNT
			22306 - West 112th Street
	1	Base Work Only	\$ -
	2	Commission's Contract Contingency	\$ 395,000.00
	3	Sitework Allowance	\$ 25,000.00
	4	<b>TOTAL BASE BID</b>	<b>\$ 420,000.00</b>
	Accepted by the Commission		<input type="checkbox"/>
South Loomis St.	LINE	DESCRIPTION	AMOUNT
			22307 - South Loomis Street
	5	Base Work Only	\$ -
	6	Commission's Contract Contingency	\$ 245,000.00
	7	Sitework Allowance	\$ 25,000.00
	8	<b>TOTAL BASE BID</b>	<b>\$ 270,000.00</b>
	Accepted by the Commission		<input type="checkbox"/>
	LINE	DESCRIPTION	TOTAL AMOUNTS
	9	<b>GRAND TOTAL BASE BID - ALL STREETS (Total of Lines 4 and 8)</b>	<b>\$ 690,000.00</b>
	10	<b>GRAND TOTAL AWARD CRITERIA FIGURE - ALL STREETS</b>	<b>\$ 690,000.00</b>

# Highlights

## THE BID FORM

SURETY INFORMATION <small>(Provide Legal Name and address of Surety)</small>			
Name:	<input type="text"/>		
Address:	<input type="text"/>		

BIDDER'S INFORMATION			
<u>Master Bid Tab</u>	22306 W. 112th	22307 S. Loomis	Award Criteria Figure



**Each Street/Avenue has a separate tab  
(2 TOTAL)**

**Enter your unit pricing for TWO (2) Streets**

**The Master Bid Form will automatically TOTAL**

# Highlights

## THE BID FORM - SCHEDULE OF PRICES

SCHEDULE OF PRICES							
CHICAGO DEPARTMENT OF TRANSPORTATION WORKS PROGRESS ADMINISTRATION ("WPA") STREET RECONSTRUCTION							
LOCATION: W. 112th St. (from S. Fairfield Ave. to S. Rockwell St.)							
CDOT PROJECT NO.: B-4-306 PBC PROJECT NO.: 22306							
PBC CONTRACT: C1617							
Bidder's pricing for each line item should carry its share of the costs of work, plus its share of overhead and profit. Bidders should avoid nominal pricing for some lines and enhanced pricing for other lines.							
Bids that the PBC considers to be materially unbalanced will be rejected.							
Line	Code Number	Description	Unit	Estimated Quantity	Unit Price	Cost	
1	20100110	TREE REMOVAL (6 TO 15 UNITS DIAMETER)	UNIT	14		-	
2	20100210	TREE REMOVAL (OVER 15 UNITS DIAMETER)	UNIT	16		-	
3	2010100C	TREE PROTECTION	EACH	18		-	
4	20101210C	ROOT PRUNING	FOOT	240		-	
5	20200100	EARTH EXCAVATION	CU YD	3431		-	
6	20700220C	POROUS GRANULAR EMBANKMENT, SUBGRADE	CU YD	133		-	
7	20800150	TRENCH BACKFILL	CU YD	60		-	
8	20820200C	TRENCH BACKFILL, WATERMAIN	CU YD	210		-	
9	21101615	TOPSOIL FURNISH AND PLACE, 4-INCH	SQ YD	1726		-	
10	251K0100C	SHREDDED HARDWOOD BARK MULCH	SQ YD	24		-	
11	CDOT25200110	SODDING, SALT TOLERANT	SQ YD	1726		-	
89	81420120C	HANDHOLE, ELECTRIC, WITH 24" FRAME AND COVER	EACH	2		-	
90	81420400C	CLEAN EXISTING CITY MANHOLE OR HANDHOLE	EACH	3		-	
91	81420500C	DRILL EXISTING ELECTRIC HANDHOLE OR MANHOLE	EACH	2		-	
92	81720220C	ELECTRIC CABLE IN CONDUIT, TRIPLEX, 2-1/2" NO. 6, 1-1/2" NO. 8 GROUND	FOOT	1926		-	
93	81820120C	RACK, SECONDARY AERIAL 3 WIRE	EACH	4		-	
94	82120300C	LUMINAIRE, LED, ACORN, ARTERIAL, RESIDENTIAL	EACH	10		-	
95	82120860C	LUMINAIRE, LED, COBRA HEAD, RESIDENTIAL	EACH	10		-	
96	82121300C	LUMINAIRE NODE, INTERNAL	EACH	10		-	
97	82520200C	CONTROLLER, STREET LIGHTING, POLE MOUNTED, CONSTANT POWER, 1-PHASE, 120/240V, 60A	EACH	3		-	
98	83000023C	LIGHT POLE, ALUMINUM, DAVIT, 18 FT. M.H., 8 FT DAVIT ARM	EACH	10		-	
99	83620210C	LIGHT POLE FOUNDATION, METAL, 10" BOLT CIRCLE, 8 5/8" X 5'	EACH	12		-	
100	84400105	RELOCATE EXISTING LIGHTING UNIT	EACH	2		-	
101	89520100C	REMOVE EXISTING STREET LIGHTING EQUIPMENT	L SUM	1		-	
102	89521100C	BREAKDOWN CONCRETE FOUNDATION, LIGHT POLE	EACH	3		-	
103	CDOT-242	AERIAL CABLE, 3-1/2" NO. 4 WITH MESSENGER WIRE	LN FT	680		-	
104	TOTAL FOR 22306/B-4-306 - W. 112th St.					\$	-

Enter your unit pricing HERE

Sheet will automatically TOTAL HERE



# Highlights

## THE BID FORM - MASTER BID TOTAL & ADDT'L INFO

LINE	DESCRIPTION	TOTAL AMOUNTS	
9	GRAND TOTAL BASE BID - ALL STREETS (Total of Lines 4 and 8)	\$	690,000.00
10	GRAND TOTAL AWARD CRITERIA FIGURE - ALL STREETS	\$	690,000.00
<b>SURETY INFORMATION</b> (Provide Legal Name and address of Surety)			
Name: _____			
Address: _____			
<b>BIDDER'S INFORMATION</b>			
Firm Name: _____			
Date: _____			

Enter your Surety & Firm Information HERE

The TOTAL from ALL streets/avenues will automatically populate HERE



# Highlights

PROJECT Chicago Department of Transportation Works  
 NAME: Progress Administration ("WPA") Street  
 LOCATION: West 112th Street & South Loomis Street  
 CONTRACT N C1617  
 PROJECT 22306 and 22307

## AWARD CRITERIA FIGURE FORMULA

	FORMULA
<b>Line 1. (Based on Grand Total Base Bid)</b>	#####
Line 2. Minority Journeyman (Maximum figure 0.70)	
Line 3. Multiply Line 2 by Line 1 by 0.04	\$0.00
	\$690,000.00
Line 4. Minority Apprentice (Maximum figure 0.70)	
Line 5. Multiply Line 4 by Line 1 by 0.03	\$0.00
	\$690,000.00
Line 6. Minority Laborer (Maximum figure 0.70)	
Line 7. Multiply Line 6 by Line 1 by 0.01	\$0.00
	\$690,000.00
Line 8. Female Journeyman (Maximum figure 0.15)	
Line 9. Multiply Line 8 by Line 1 by 0.04	\$0.00
	\$690,000.00
Line 10. Female Apprentice (Maximum figure 0.15)	
Line 11. Multiply Line 10 by Line 1 by 0.03	\$0.00
	\$690,000.00
Line 12. Female Laborer (Maximum figure 0.15)	
Line 13. Multiply Line 12 by Line 1 by 0.01	\$0.00
	\$690,000.00
Line 14. Total of Lines 3, 5, 7, 9, 11, and 13	\$0.00
Line 15. Total Award Criteria	\$690,000.00
<b>TOTAL AWARD CRITERIA (Line 15)</b>	#####

Accepted by the Commission

## BIDDER'S INFORMATION

Firm Name:  
 Date:

## NOTES/INSTRUCTIONS

- Prior to submitting your bid electronically, please do the following:
  - Enter Line 2, 4, 6, 8, 10, and 12 in the Formula column and the Bidder's Information section have been populated.
  - Save the file.
  - Convert the file to PDF.
  - Include copy of the Award Criteria Figure worksheet **within** the scanned copy of the bid.
  - Attach the PDF version, **along with** the scanned copy of the bid.
  - Send email to: jamez.barkman@cityofchicago.org and pbc-prcurement@cityofchicago.org.
- Line 1. (Based on Total Base Bid) automatically populate from Bid Form.
- Bidder is to populate Line 2, 4, 6, 8, 10, and 12 (field is shaded Light Green).
- Line 2, 4, 6, 8, 10, and 12 are to be entered in decimal. (ie 5% participation - 0.05, 15% participation - 0.15, 50% participation - .50)
- Line 15. **TOTAL AWARD CRITERIA** automatically populate.

# AWARD CRITERIA FIGURE

## BASIS OF AWARD

(Book 1, Page 10)

- Award will be made to the Responsible Bidder submitting the **Lowest Grand Total Award Criteria Figure (Line 10 of Bid Form)** whose corresponding Grand Total Base Bid (Line 9 of Bid Form) is within the Available Funds for each street/avenue and is otherwise responsive to all requirements of the Contract Documents.
- Firms are required to **fill out the entire BID FORM** to be considered responsive.
- The Commission reserves the right to reject any and all bids wherever such rejection is in the best interest of the Commission.
- Bids that the PBC considers to be materially unbalanced will be rejected.



# Compliance

# Compliance

## MBE/WBE PARTICIPATION

### MBE/WBE Goals

26%, MBE

6%, WBE

### MBE/WBE Certifications

- City of Chicago
- Cook County

### MBE/WBE Special Conditions

Book 2, Article 23

#### Compliance: Certification

---

PBC ensures that only certified and experienced firms perform the required services.

**MBE or WBE firms must be certified with the City of Chicago and/or Cook County to be counted as an MBE/WBE firm by the PBC.**



## Award Criteria Figure

Maximum **70%**

Minority Journeyworker,  
Apprentice, and;  
Laborer

Maximum **15%**

Female Journeyworker,  
Apprentice, and;  
Laborer

## City Residency & Community Hiring

PBC encourages the creation of career opportunities for residents of a project's surrounding community areas, both in the construction trades as well as skilled and unskilled workers.

- ☑ **Community hiring goal:** at least **7.5%** of project labor performed by community residents
- ☑ **City residency goal:** at least **50%** of project labor performed by residents of the city of Chicago



EXHIBIT #3 - Community Area Map

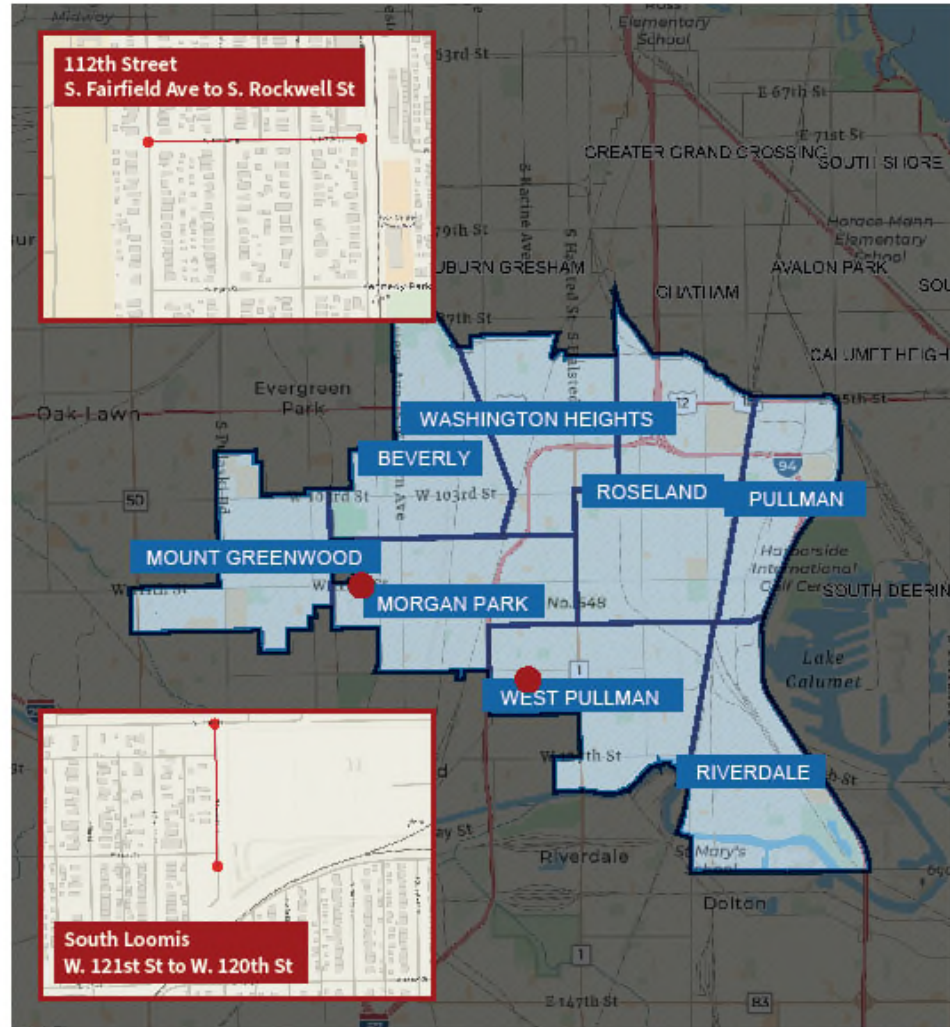

CDOT Works Progress Administration ("WPA") Street West 112th Street & South Loomis Street

- Project location
- Project Area
- Community Areas

## Community Hiring MAP

## MBE/WBE COMPLIANCE

### Documentation and Monitoring

- B2Gnow: MBE/WBE Compliance monitoring
- Established Business, Manufacturers, Suppliers, and Brokers
- Schedule D
- Schedule C

# Compliance

## PUBLIC BUILDING COMMISSION OF CHICAGO

### SCHEDULE D - Affidavit of General Contractor Regarding MBE/WBE Participation (1 of 2)

Name of Project: \_\_\_\_\_

STATE OF ILLINOIS    )  
                                  )SS  
COUNTY OF COOK    )

In connection with the above-captioned contract, I HEREBY DECLARE AND AFFIRM that I am the

\_\_\_\_\_ Title and duly authorized representative of

\_\_\_\_\_ Name of General Contractor whose address is

\_\_\_\_\_ in the City of \_\_\_\_\_, State of \_\_\_\_\_ and that I have personally reviewed the material and facts submitted with the attached Schedules of MBE/WBE participation in the above-referenced Contract, including Schedule C and Schedule B (if applicable), and the following is a statement of the extent to which MBE/WBE firms will participate in this Contract if awarded to this firm as the Contractor for the Project.

Name of MBE/WBE Contractor	Type of Work to be Done in Accordance with Schedule C	Dollar Credit Toward MBE/WBE Goals	
		MBE	WBE
		\$	\$
		\$	\$
		\$	\$
		\$	\$
		\$	\$
		\$	\$
		\$	\$
		\$	\$
		\$	\$
<b>Total Net MBE/WBE Credit</b>		\$	\$
<b>Percent of Total Base Bid</b>		%	%

The General Contractor may count toward its MBE/WBE goal a portion of the total dollar value of a contract with a joint venture equal to the percentage of the ownership and control of the MBE/WBE partner.

# Schedule D

## PUBLIC BUILDING COMMISSION OF CHICAGO

### SCHEDULE D - Affidavit of General Contractor Regarding MBE/WBE Participation (2 of 2)

The Undersigned will enter into a formal agreement for the above work with the above-referenced MBE/WBE firms, conditioned upon performance as Contractor of a Contract with the Commission, and will do so within five (5) business days of receipt of a notice of Contract award from the Commission.

Additionally, the Undersigned certifies to the best of its knowledge and belief that it, its principals and any subcontractors used in the performance of this contract, meet the Agency requirements and have not violated any City or Sister Agency policy, codes, state, federal or local laws, rules or regulations and have not been subject to any debarment, suspension or other disciplinary action by any government agency. Additionally, if at any time the Contractor becomes aware of such information, it must immediately disclose it to the Commission.

BY:

\_\_\_\_\_ Name of Contractor (Print)

\_\_\_\_\_ Date

\_\_\_\_\_ Phone

IF APPLICABLE:

BY:

\_\_\_\_\_ Joint Venture Partner (Print)

\_\_\_\_\_ Date

\_\_\_\_\_ Phone/FAX

\_\_\_\_\_ Signature

\_\_\_\_\_ Name (Print)

\_\_\_\_\_ Signature

\_\_\_\_\_ Name (Print)

MBE \_\_\_ WBE \_\_\_ Non-MBE/WBE \_\_\_





# Compliance

## Schedule C

### PUBLIC BUILDING COMMISSION OF CHICAGO

#### SCHEDULE C - Letter of Intent from MBE/WBE (1 of 2) To Perform As Subcontractor, Subconsultant, and/or Material Supplier

Name of Project: \_\_\_\_\_

Project Number: \_\_\_\_\_

FROM:

\_\_\_\_\_  
(Name of MBE or WBE) MBE \_\_\_\_\_ WBE \_\_\_\_\_

TO:

\_\_\_\_\_ and Public Building Commission of Chicago  
(Name of Bidder)

The undersigned intends to perform work in connection with the above-referenced project as (check one):

\_\_\_\_\_ a Sole Proprietor                      \_\_\_\_\_ a Corporation  
\_\_\_\_\_ a Partnership                              \_\_\_\_\_ a Joint Venture

The MBE/WBE status of the undersigned is confirmed by the attached Letter of Certification, dated \_\_\_\_\_, In addition, in the case where the undersigned is a Joint Venture with a non-MBE/WBE firm, a Schedule B, Joint Venture Affidavit, is provided.

The undersigned is prepared to provide the following described services or supply the following described goods in connection with the above-named project.

\_\_\_\_\_  
\_\_\_\_\_  
\_\_\_\_\_  
\_\_\_\_\_

The above-described services or goods are offered for the following price, with terms of payment as stipulated in the Contract Documents.

\_\_\_\_\_  
\_\_\_\_\_  
\_\_\_\_\_  
\_\_\_\_\_

### PUBLIC BUILDING COMMISSION OF CHICAGO

#### SCHEDULE C - Letter of Intent from MBE/WBE (2 of 2) To Perform As Subcontractor, Subconsultant, and/or Material Supplier

##### PARTIAL PAY ITEMS

For any of the above items that are partial pay items, specifically describe the work and subcontract dollar amount:

\_\_\_\_\_  
\_\_\_\_\_  
\_\_\_\_\_

If more space is needed to fully describe the MBE/WBE firm's proposed scope of work and/or payment schedule, attach additional sheet(s).

##### SUB-SUBCONTRACTING LEVELS\*

\_\_\_\_\_ % of the dollar value of the MBE/WBE subcontract will be sublet to non-MBE/WBE contractors.

\_\_\_\_\_ % of the dollar value of the MBE/WBE subcontract will be sublet to MBE/WBE contractors.

**\*If MBE/WBE subcontractor will not be sub-subcontracting any of the work described in this Schedule, a zero (0) must be filled in each blank above. If more than 10% percent of the value of the MBE/WBE subcontractor's scope of work will be sublet, a brief explanation and description of the work to be sublet must be provided.**

The Undersigned (Contractor) will enter into a formal agreement for the above work with the Bidder, conditioned upon its execution of a contract with the Public Building Commission of Chicago, and will do so within five (5) working days of receipt of a notice of Contract award from the Commission.

Additionally, the Undersigned certifies to the best of its knowledge and belief that it, its principals and any subcontractors used in the performance of this contract, meet the Agency requirements and have not violated any City or Sister Agency policy, codes, state, federal or local laws, rules or regulations and have not been subject to any debarment, suspension or other disciplinary action by any government agency. Additionally, if at any time the Contractor becomes aware of such information, it must immediately disclose it to the Commission.

BY:

\_\_\_\_\_  
Name of MBE/WBE Firm (Print)

\_\_\_\_\_  
Date

\_\_\_\_\_  
Phone

IF APPLICABLE:

BY:

\_\_\_\_\_  
Joint Venture Partner (Print)

\_\_\_\_\_  
Date

\_\_\_\_\_  
Phone

\_\_\_\_\_  
Signature

\_\_\_\_\_  
Name (Print)

\_\_\_\_\_  
Signature

\_\_\_\_\_  
Name (Print)

MBE \_\_\_\_\_ WBE \_\_\_\_\_ Non-MBE/WBE \_\_\_\_\_

# PBC CONTACT

**James Borkman**

[james.borkman@cityofchicago.org](mailto:james.borkman@cityofchicago.org)



# Technical Review

# Project Overview

## Project Locations

- S Loomis St - W 121<sup>st</sup> St to W 120<sup>th</sup> St
- W 112<sup>th</sup> St - S Fairfield Ave to S Rockwell St



# Project Overview

## Project Locations

- S Loomis St – W 121<sup>st</sup> St to W 120<sup>th</sup> St
- W 112<sup>th</sup> St – S Fairfield Ave to S Rockwell St

### Existing Conditions

- No curb and gutter
- Right-of-Way is 33'
- Existing roadway width varies between 14' and 19'



## Project Overview

- Existing Conditions
- Proposed Work

# Project Overview

## Project Locations

- S Loomis St - W 121<sup>st</sup> St to W 120<sup>th</sup> St
- W 112<sup>th</sup> St - S Fairfield Ave to S Rockwell St

### Existing Conditions

- Four driveways
- One alley apron
- Parking in west parkway

## Project Overview

- Existing Conditions
- Proposed Work

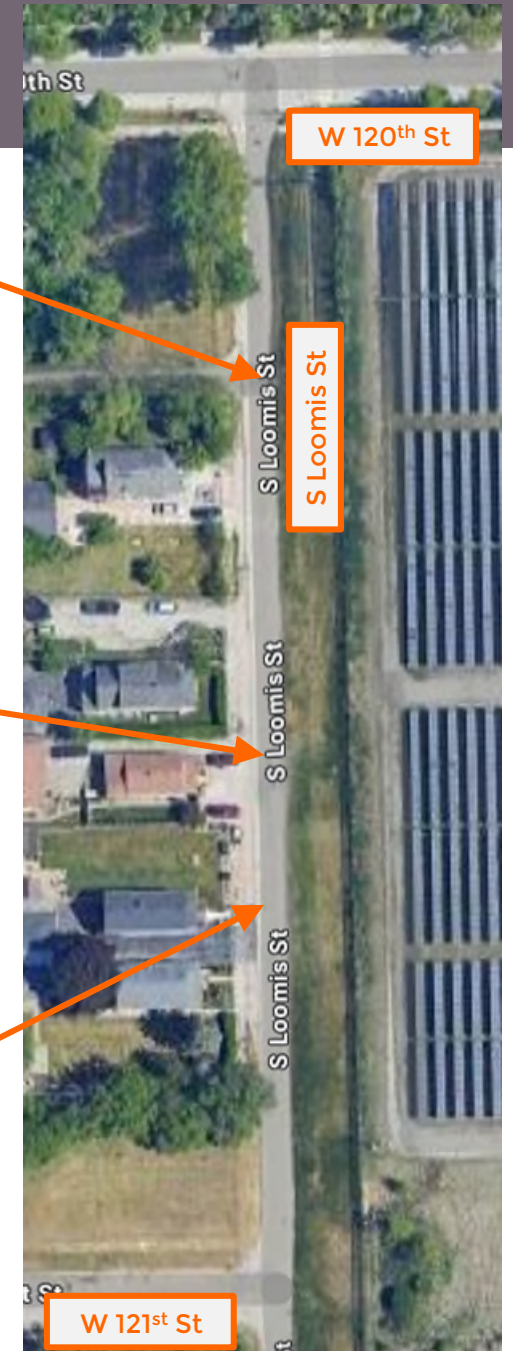

# Project Overview

## Project Locations

- S Loomis St – W 121<sup>st</sup> St to W 120<sup>th</sup> St
- W 112<sup>th</sup> St – S Fairfield Ave to S Rockwell St
- Existing Conditions
  - Environmental report available in Book 3, Appendix C Part 2
  - Soil Disposal Classification is Landfill as Non-Special Waste

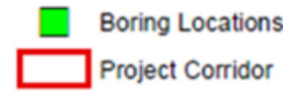

## Project Overview

- Existing Conditions
- Proposed Work

Table 6. Soil Disposal Description Summary

Soil Boring	Soil Interval (ft)	Sample Classification	Analyte(s) Exceeding the MAC(s)	Eligible for CCDD or USFO Disposal	Soil Disposal Classification
SB-X	1-3	669.05(a)(5)	Benzo(a)pyrene* Arsenic	No	Landfill as Non-Special Waste (NSW)
	4-6	669.05(a)(5)	Arsenic	No	Landfill as Non-Special Waste (NSW)
SB-Y	3-5	669.05(a)(5)	Benzo(a)pyrene* Lead	No	Landfill as Non-Special Waste (NSW)
	6-7	669.05(a)(5)	Arsenic	No	Landfill as Non-Special Waste (NSW)

\* Exceeded only the MAC value for CCDD disposal facilities *Outside a Populated Area*

# Project Overview

## Project Locations

- **S Loomis St - W 121<sup>st</sup> St to W 120<sup>th</sup> St**
- **W 112<sup>th</sup> St - S Fairfield Ave to S Rockwell St**

### Proposed Work

- Full depth pavement reconstruction
- Widen roadway width to 18' and install curb and gutter
- 6' of 8" ESVCVP, 36' of 18" DIP, 19' of 24" DIP sewer
- Install two Catch Basins, one manhole
- Construct one alley and four driveway aprons
- Construct five parallel parking stalls
- Construct two ADA corners

## Project Overview

- Existing Conditions
- Proposed Work

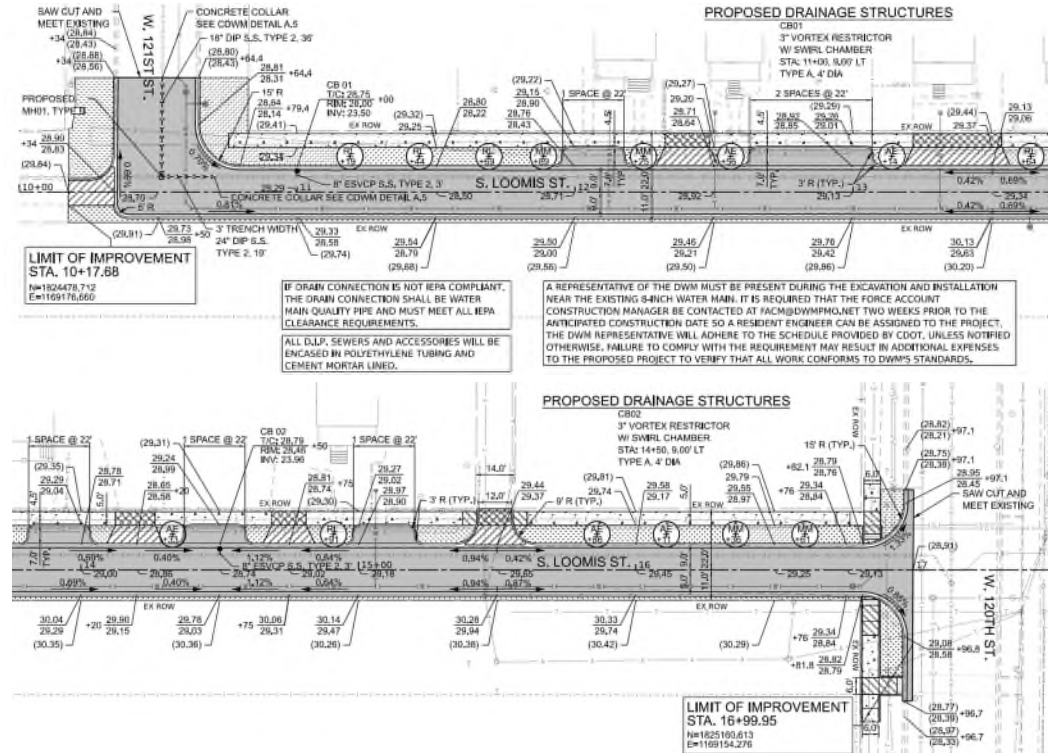



# Project Overview

## Project Locations

- **S Loomis St - W 121<sup>st</sup> St to W 120<sup>th</sup> St**
- W 112<sup>th</sup> St - S Fairfield Ave to S Rockwell St
- **Proposed Work**
  - 691' of DIP water main
  - Install two water valve basins
  - Replace 173' of 3/4" water service line
  - Install five service control valves
  - Install two fire hydrants

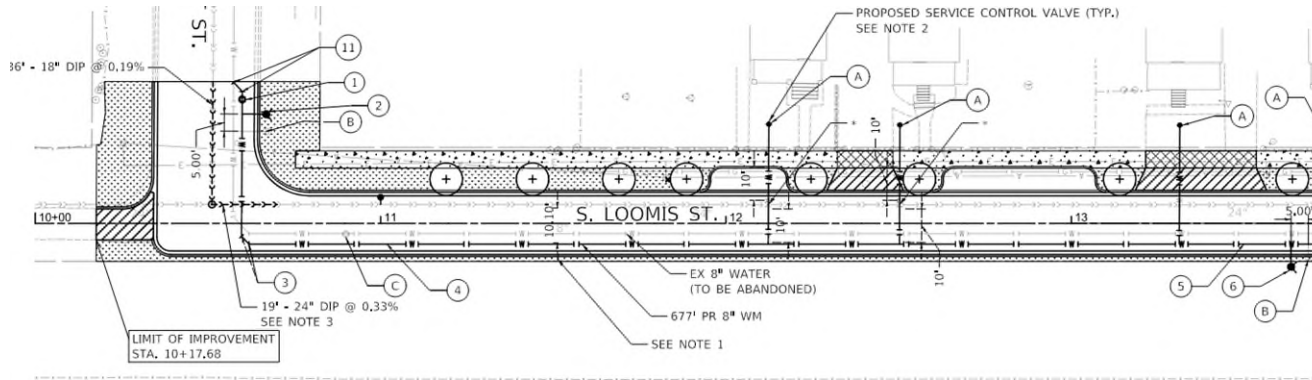

## Project Overview

- Existing Conditions
- Proposed Work

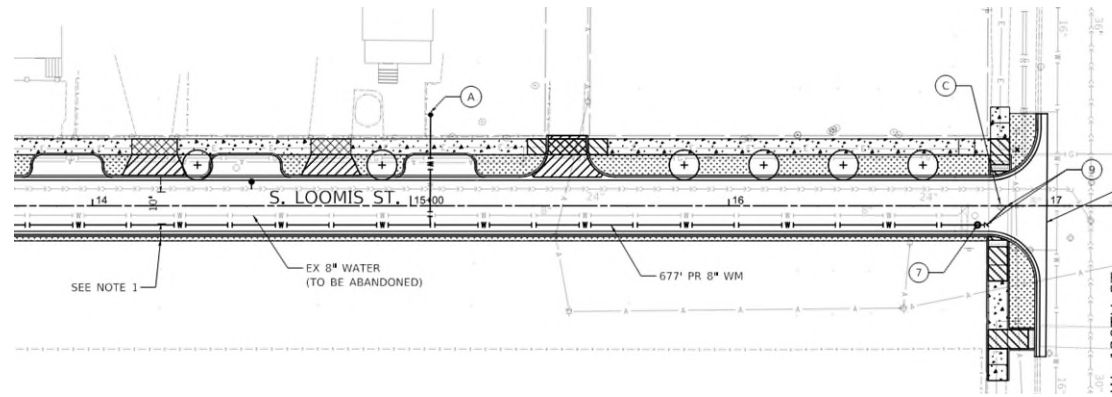

# Project Overview

## Project Locations

- S Loomis St - W 121st St to W 120th St
- **W 112<sup>th</sup> St - S Fairfield Ave to S Rockwell St**

- **Existing Conditions**

- No curb and gutter
- Existing roadway width varies between 20' and 32'



## Project Overview

- **Existing Conditions**
- Proposed Work



# Project Overview

## Project Locations

- S Loomis St - W 121st St to W 120th St
- **W 112<sup>th</sup> St - S Fairfield Ave to S Rockwell St**

- **Existing Conditions**

- Ten driveways
- Three alley aprons



## Project Overview

- **Existing Conditions**
- Proposed Work



# Project Overview

## Project Locations

- S Loomis St - W 121st St to W 120th St
- **W 112<sup>th</sup> St - S Fairfield Ave to S Rockwell St**

■ Boring Locations  
 Project Corridor



### Existing Conditions

- Environmental report available in Book 3, Appendix C Part 1
- Soil Disposal Classification is Landfill as Non-Special Waste

Table 5. Soil Disposal Description Summary

Soil Boring	Soil Interval (ft)	Sample Classification	Analyte(s) Exceeding the MAC(s)	Eligible for CCDD or USFO Disposal	Soil Disposal Classification
SB-W	0-5	669.05(a)(5)	Benzo(a)anthracene Benzo(a)pyrene Benzo(b)fluoranthene Benzo(k)fluoranthene Dibenz(a,h)anthracene Indeno(1,2,3-cd)pyrene	No	Landfill as Non-Special Waste (NSW)
SB-W	5-12	669.05(a)(5)	None	No. PID reading >1 ppm	Landfill as Non-Special Waste (NSW)

## Project Overview

- Existing Conditions
- Proposed Work



# Project Overview

## Project Locations

- S Loomis St - W 121st St to W 120th St
- **W 112th St - S Fairfield Ave to S Rockwell St**
- **Proposed Work**
  - Full depth pavement reconstruction
  - Widen roadway width to 30' and install curb and gutter
  - Pavement resurfacing at S. Fairfield Ave.
  - Install eight Catch Basins
  - 43' of 8" ESVCP, 95' of 8" DIP sewer
  - Construct three alleys and twelve driveway aprons
  - Construct eleven ADA corners

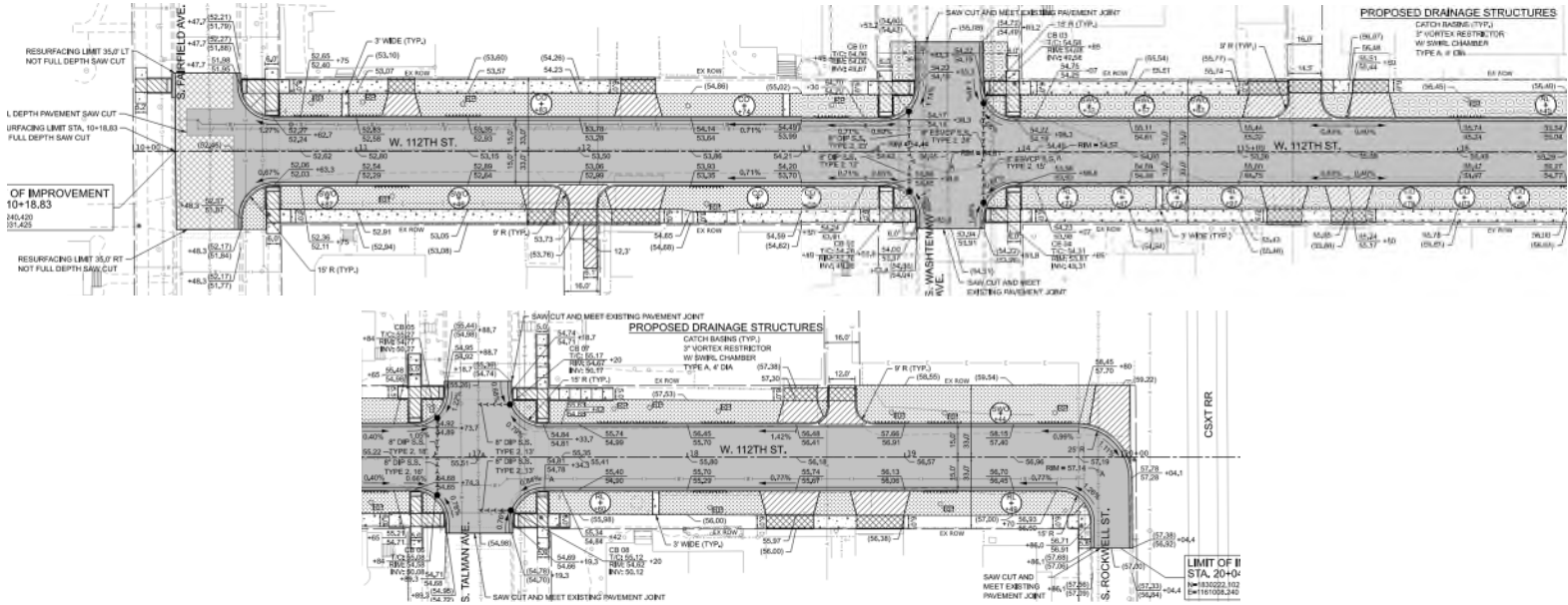

## Project Overview

- Existing Conditions
- **Proposed Work**



# Project Overview

## Project Locations

- S Loomis St - W 121st St to W 120th St
- **W 112<sup>th</sup> St - S Fairfield Ave to S Rockwell St**
- **Proposed Work**

- 419' of DIP water main
- Install two water valve basins
- Replace 68' of 1" water service line
- Install two service control valves
- Install one fire hydrant

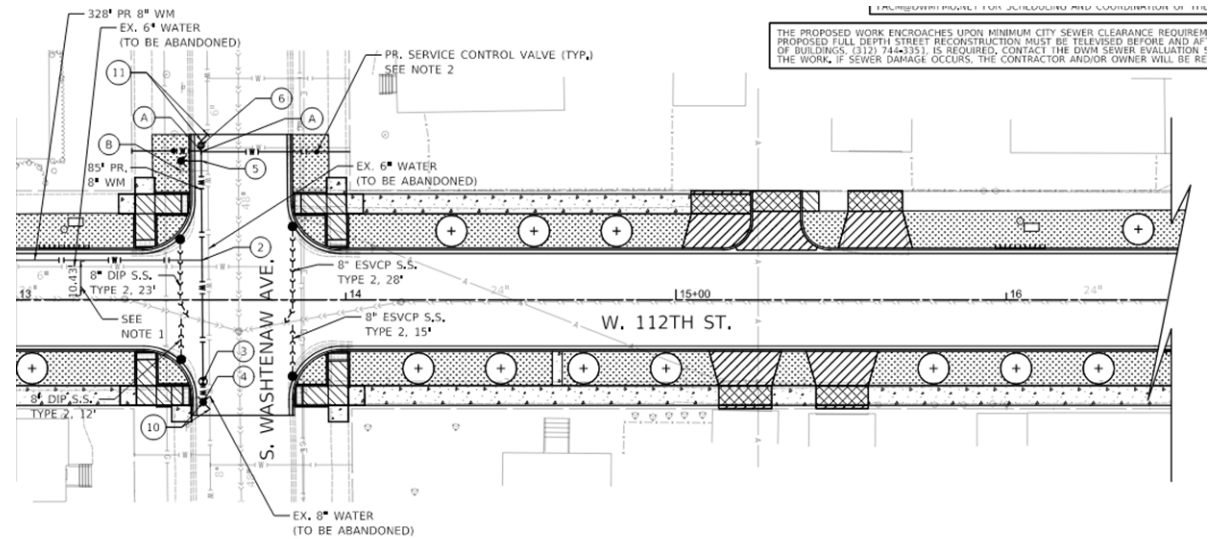
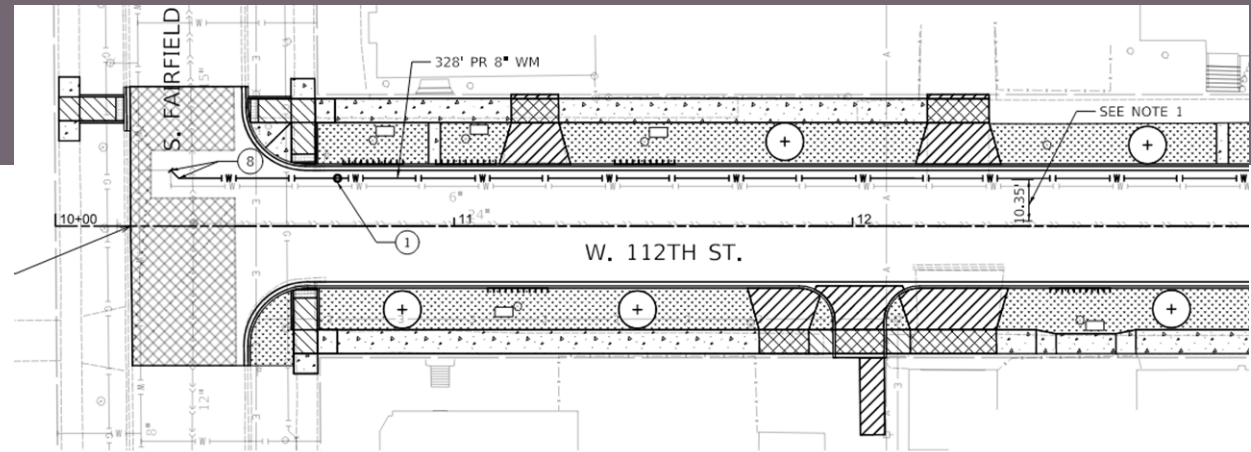

## Project Overview

- Existing Conditions
- **Proposed Work**



# Project Overview

## Project Locations

- **S Loomis St - W 121st St to W 120th St**
- **W 112<sup>th</sup> St - S Fairfield Ave to S Rockwell St**

### Proposed Landscaping

- Refer to contract documents for removal or protection of existing trees and root pruning limits
- New trees to be planted in the parkways
- New grass sod to be placed in the parkways

## Project Overview

- Existing Conditions
- Proposed Work

### Loomis St

SYMBOL	NAME	COMMON NAME	QUANTITY
⊕ <sub>AE</sub>	ULMUS CARPINIFOLIA MORTON	ACCOLADE ELM	5 EACH
⊕ <sub>RL</sub>	TILIA AMERICANA	REDMOND LINDEN	5 EACH
⊕ <sub>MM</sub>	ACER FREEMANII	MARMO MAPLE	4 EACH
		TOTALS	14 EACH

### 112<sup>th</sup> St

SYMBOL	NAME	COMMON NAME	QUANTITY
⊕ <sub>RL</sub>	TILIA AMERICANA REDMOND	REDMOND LINDEN	7 EACH
⊕ <sub>CO</sub>	CELTIS OCCIDENTALIS CHICAGOLAND	CHICAGOLAND HACKBERRY	7 EACH
⊕ <sub>SWO</sub>	QUERCUS BICOLOR	SWAMP WHITE OAK	6 EACH
		TOTALS	20 EACH

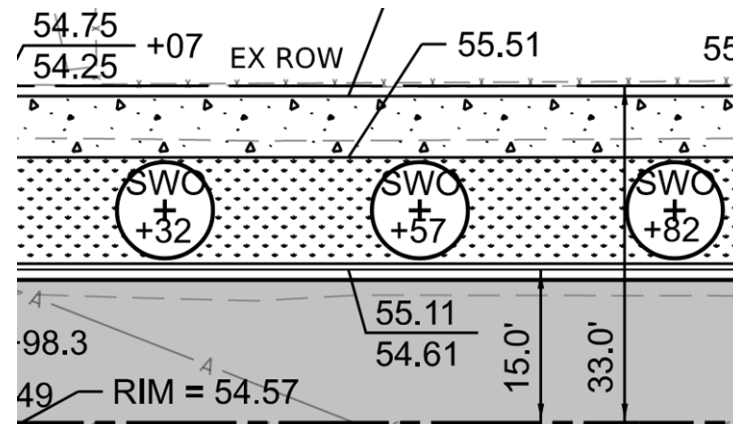
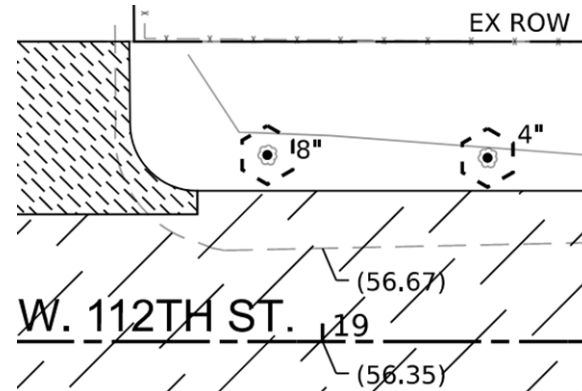

# Project Overview

## Project Locations

- S Loomis St - W 121st St to W 120th St
- W 112<sup>th</sup> St - S Fairfield Ave to S Rockwell St

### Proposed Lighting

- Install new street lighting including piggyback lighting for pedestrians
- One light pole provides lighting for both the street and sidewalk
- Upgraded LED lamps

## Project Overview

- Existing Conditions
- Proposed Work



Existing Street Lighting



Proposed Street Lighting



# Q & A