



ADDENDUM

Public Building Commission of Chicago | Richard J. Daley Center | 50 West Washington Street, Room 200 | Chicago, Illinois 60602 | (312) 744-3090 | pbccchicago.com

ADDENDUM NO.: 03
PROJECT NAME: Williams Park Fieldhouse
PROJECT NO.: 11320
CONTRACT NO.: C1593
DATE OF ISSUE: January 22, 2018

NOTICE OF CHANGES, MODIFICATIONS, OR CLARIFICATIONS TO CONTRACT DOCUMENTS

The following changes, modifications, or clarifications are hereby incorporated and made an integral part of the Contract Documents. Unless clearly expressed otherwise by this Addendum, all terms and conditions defined in the original Contract Documents shall continue in full force and effect and shall have the same meaning in this Addendum. Issued Addenda represent responses/clarifications to various inquiries. Contractors shall be responsible for including all associated labor/material costs in its bid. Drawings/specifications corresponding to inquiry responses will be issued with the Issue for Construction Documents, upon issuance of building permit.

- ITEM NO. 1: CHANGE TO KEY DATES**
None.
- ITEM NO. 2: REVISIONS TO BOOK 1 – PBC INSTRUCTIONS TO BIDDERS**
None.
- ITEM NO. 3: REVISIONS TO BOOK 2 – PBC STANDARD TERMS AND CONDITIONS**
None.
- ITEM NO. 4: REVISIONS TO BOOK 3 – TECHNICAL SPECIFICATIONS**
Change 1 Book 3 – Volume 1 – **REPLACED**– 00 01 10 – Table of Contents
Change 2 Book 3 – Volume 1 – **REMOVED**– 02 83 19.13 – Lead Based Paint Abatement
Change 3 Book 3 – Volume 1 – **REPLACED**– 00 01 11 – Information available to bidders.
Change 4 Book 4 – **ADDED** – Environmental Consulting Group, Inc. Lead-Based paint abatement clarification letter
- ITEM NO. 5: REVISIONS TO DRAWINGS**
Change 1 **REVISED** – Drawing No C1.7 Construction Details – Added more information to Underground detention typical section detail.
- ITEM NO. 6: REQUESTS FOR INFORMATION**
None.

List of Attachments and Drawings:

This Addendum includes the following attached Specifications and/or Documents:

1. Section 00 01 10 – Table of Contents
2. Section 00 01 11 – Information available to bidders
3. Environmental Consulting Group, Inc. Lead-Based paint abatement clarification letter

This Addendum includes the following attached Drawings:

1. C1.7 – Construction Details, dated 1.15.2018

END OF ADDENDUM NO. 03

SECTION 00 01 10
PROJECT MANUAL, BOOK THREE
TABLE OF CONTENTS

INTRODUCTORY INFORMATION

| <i>Section Number</i> | <i>Section Title</i> | <i>Control Rev.</i> |
|-----------------------|-------------------------------|---------------------|
| 00 00 00 | PBC Project Manual Cover Page | PBC 01_02/23/17 |
| 00 01 10 | Table of Contents | PBC 00_07/07/17 |

VOLUME 1 OF 2

| | | |
|----------|-------------------------------------|-----------------|
| 00 01 11 | Info Available to Bidders – Reports | PBC 01_04/01/15 |
|----------|-------------------------------------|-----------------|

SPECIFICATIONS GROUP

GENERAL REQUIREMENTS SUBGROUP

DIVISION 01 – GENERAL REQUIREMENTS

| <i>Section Number</i> | <i>Section Title</i> | <i>Control Rev.</i> |
|-----------------------|---|---------------------|
| 01 14 10 | Pre-Construction Mockup | PBC 01_07/31/10 |
| 01 14 11 | Construction Operations and Site Utilization Plan | PBC 01_08/15/14 |
| 01 35 59 | Indoor Air Quality Requirements | PBC 04_02/08/13 |
| 01 35 60 | Sustainability Requirements | PBC 05_09/22/14 |
| 01 35 62 | Erosion and Sedimentation Control | PBC 01_09/14/12 |
| 01 50 05 | Temporary Facilities and Controls | 04_07/20/09 |
| 01 50 10 | Commission Representative Field Office | PBC 04_04/03/17 |
| 01 52 40 | Construction Waste Management and Disposal | PBC 03_09/22/14 |
| 01 56 11 | Temporary Dust, Fume, and Odor Control | 01_01/21/10 |
| 01 56 39 | Tree and Landscape Protection | |
| 01 57 15 | Integrated Pest Management | PBC 01_09/11/11 |
| 01 73 10 | Cutting and Patching | PBC 03_07/20/09 |
| 01 74 19 | Soil Disposal | |
| 01 79 00 | Demonstration and Training | PBC 03_07/20/09 |

FACILITY CONSTRUCTION SUBGROUP

DIVISION 02 – EXISTING CONDITIONS

| <i>Section Number</i> | <i>Section Title</i> | <i>Control Rev.</i> |
|-----------------------|--------------------------------|---------------------|
| 02 24 01 | Environmental Scope Sheets | PBC 01_04/01/15 |
| 02 26 00 | Hazardous Materials Assessment | PBC 01_09/18/12 |
| 02 41 16 | Structure Demolition | |

| | | |
|--------------------------|--------------|-------------------|
| Williams Park Fieldhouse | 00 01 10 - 1 | TABLE OF CONTENTS |
| PBC Project Number 11320 | | |

| | | |
|------------------------|--|----------------------------|
| 02 82 13 | Asbestos Abatement – Prior to Demolition | PBC 01_07/31/15 |
| 02 82 14 | Asbestos Abatement – Interiors | PBC 01_07/31/15 |
| 02 82 15 | Asbestos Abatement – Exteriors | PBC 01_07/31/15 |
| 02 86 13 | Hazardous and Universal Waste Management | PBC 01_07/31/15 |
| 02 83 19.13 | Lead-Based Paint Abatement | PBC 01_07/31/15 |

DIVISION 03 – CONCRETE

| <i>Section Number</i> | <i>Section Title</i> |
|-----------------------|--|
| 03 30 00 | Cast-in-place Concrete |
| 03 30 00.13 | Concrete Mix Design Submittal Form |
| 03 30 00.23 | Admixture Compatibility Certification Letter |
| 03 33 00 | Architectural Concrete |
| 03 36 00 | Special Concrete Floor Finish |

DIVISION 04 - MASONRY

| <i>Section Number</i> | <i>Section Title</i> |
|-----------------------|--------------------------|
| 04 42 00 | Dimension Stone Cladding |

DIVISION 05 - METALS

| <i>Section Number</i> | <i>Section Title</i> |
|-----------------------|---------------------------|
| 05 12 00 | Structural Steel Framing |
| 05 31 00 | Steel Decking |
| 05 40 00 | Cold-Formed Metal Framing |
| 05 50 00 | Metal Fabrications |

DIVISION 06 - WOOD, PLASTICS, AND COMPOSITES

| <i>Section Number</i> | <i>Section Title</i> |
|-----------------------|------------------------------|
| 06 10 00 | Rough Carpentry |
| 06 16 00 | Sheathing |
| 06 18 00 | Glued-Laminated Construction |
| 06 40 00 | Architectural Woodwork |
| 06 61 16 | Solid Surfacing |

DIVISION 07 - THERMAL AND MOISTURE PROTECTION

| <i>Section Number</i> | <i>Section Title</i> |
|-----------------------|------------------------------------|
| 07 21 00 | Thermal Insulation |
| 07 27 26 | Fluid-applied Membrane Air Barrier |
| 07 31 16.19 | Flat-Lock Metal Wall Panels |
| 07 42 13.19 | Insulated Metal Wall Panels |
| 07 54 19 | Polyvinyl-Chloride (PVC) Roofing |
| 07 62 00 | Sheet Metal Flashing and Trim |
| 07 71 00 | Roof Specialties |
| 07 72 00 | Roof Accessories |
| 07 81 00 | Applied Fireproofing |
| 07 84 13 | Penetration Firestopping |

07 92 00 Joint Sealant
DIVISION 08 - OPENINGS

| <i>Section Number</i> | <i>Section Title</i> |
|-----------------------|---|
| 08 11 13 | Hollow Metal Doors and Frames |
| 08 14 16 | Flush Wood Doors |
| 08 31 13 | Access Doors and Frames |
| 08 41 13 | Aluminum-Framed Entrances and Storefronts |
| 08 41 26 | All-Glass Entrances and Storefronts |
| 08 71 00 | Door Hardware |
| 08 71 63 | Automatic Door Operators |
| 08 80 00 | Glazing |
| 08 83 00 | Mirrors |

DIVISION 09 - FINISHES

| <i>Section Number</i> | <i>Section Title</i> |
|-----------------------|--------------------------------|
| 09 22 16 | Non-Structural Metal Framing |
| 09 27 13 | GFRG Fabrications |
| 09 29 00 | Gypsum Board |
| 09 30 00 | Tiling |
| 09 64 66 | Wood Gymnasium Flooring |
| 09 65 13 | Resilient Base and Accessories |
| 09 91 00 | Finish Painting |

DIVISION 10 - SPECIALTIES

| <i>Section Number</i> | <i>Section Title</i> |
|-----------------------|--|
| 10 11 00 | Visual Display Surfaces |
| 10 14 19 | Dimensional Letter Signage |
| 10 14 23 | Interior Signage |
| 10 14 26 | Post and Panel Signage |
| 10 21 13 | Toilet Compartments |
| 10 22 38 | Operable Panel Partitions |
| 10 28 00 | Toilet and Bath Accessories |
| 10 44 13 | Fire Extinguishers, Cabinets and Accessories |

DIVISION 11 - EQUIPMENT

| <i>Section Number</i> | <i>Section Title</i> |
|-----------------------|----------------------|
| 11 31 00 | Appliances |
| 11 66 23 | Gymnasium equipment |

DIVISION 12 - FURNISHINGS

| <i>Section Number</i> | <i>Section Title</i> |
|-----------------------|------------------------|
| 12 24 13 | Roller Window Shades |
| 12 48 16 | Entrance Floor grilles |

DIVISION 13 - SPECIAL CONSTRUCTION – NOT USED

DIVISION 14 – CONVEYING – NOT USED

VOLUME 2 OF 2

DIVISION 22 - PLUMBING

| <i>Section Number</i> | <i>Section Title</i> |
|-----------------------|--|
| 22 05 13 | Common Motor Requirements for Plumbing Equipment |
| 22 05 16 | Expansion Fittings and Loops for Plumbing Piping |
| 22 05 17 | Sleeves and Sleeve Seals for Plumbing Piping |
| 22 05 18 | Escutcheons for Plumbing Piping |
| 22 05 19 | Meters and Gages for Plumbing Piping |
| 22 05 23.12 | Ball Valves for Plumbing Piping |
| 22 05 23.13 | Butterfly Valves for Plumbing Piping |
| 22 05 23.14 | Check Valves for Plumbing Piping |
| 22 05 23.15 | Gate Valves for Plumbing Piping |
| 22 05 29 | Hangers and Supports for Plumbing Piping and Equipment |
| 22 05 33 | Heat Tracing for Plumbing Piping |
| 22 05 53 | Identification for Plumbing Piping and Equipment |
| 22 07 19 | Plumbing Piping Insulation |
| 22 11 16 | Domestic Water Piping |
| 22 11 19 | Domestic Water Piping Specialties |
| 22 11 23 | Domestic Water Pumps |
| 22 13 16 | Sanitary Waste and Vent Piping |
| 22 13 19 | Sanitary Waste Piping Specialties |
| 22 14 13 | Facility Storm Drainage Piping |
| 22 14 23 | Storm Drainage Piping Specialties |
| 22 33 00 | Electric, Domestic-Water Heaters |
| 22 42 13.13 | Commercial Water Closets |
| 22 42 13.16 | Commercial Urinals |
| 22 42 16.13 | Commercial Lavatories |
| 22 42 16.16 | Commercial Sinks |
| 22 47 13 | Drinking Fountains |

DIVISION 23 – HEATING, VENTILATING AND AIR-CONDITIONING (HVAC)

| <i>Section Number</i> | <i>Section Title</i> |
|-----------------------|--|
| 23 05 13 | Common Motor Requirements for HVAC Equipment |
| 23 05 17 | Sleeves and Seals for HVAC Piping |
| 23 05 18 | Escutcheons for HVAC Piping |
| 23 05 29 | Hangers and Supports for HVAC Piping and Equipment |
| 23 05 48.13 | Vibration Controls for HVAC |

| | |
|-------------|---|
| 23 05 53 | Identification for HVAC Piping and Equipment |
| 23 05 93 | Testing, Adjusting, And Balancing for HVAC |
| 23 07 13 | Duct Insulation |
| 23 09 00 | Instrumentation and Control For HVAC |
| 23 09 93 | Sequence of Operations for HVAC Controls |
| 23 11 23 | Facility Natural Gas Piping |
| 23 31 13 | Metal Ducts |
| 23 33 00 | Air Duct Accessories |
| 23 34 23 | HVAC Power Ventilators |
| 23 36 00 | Air Terminal Units |
| 23 37 13.13 | Air Diffusers |
| 23 37 13.23 | Air Registers and Grilles |
| 23 74 16.11 | Packaged, Small-Capacity Rooftop Air-Conditioning Units |
| 23 82 36 | Finned-Tube Radiation Heaters |
| 23 82 39.13 | Cabinet Unit Heaters |
| 23 82 39.16 | Propeller Unit Heaters |

DIVISION 25 – INTEGRATED AUTOMATION – NOT USED

DIVISION 26 – ELECTRICAL

| <i>Section Number</i> | <i>Section Title</i> |
|-----------------------|--|
| 26 05 19 | Low-Voltage Electrical Power Cables |
| 26 05 23 | Control-Voltage Electrical Power Cables |
| 26 05 26 | Grounding and Bonding for Electrical Systems |
| 26 05 29 | Hangers and Supports for Electrical Systems |
| 26 05 33 | Raceways and Boxes for Electrical Systems |
| 26 05 43 | Underground Ducts and Raceways for Electrical Systems |
| 26 05 53 | Identification for Electrical Systems |
| 26 05 74 | Short-Circuit/Coordination Study/Arc Flash Hazard Analysis |
| 26 09 23 | Lighting Control Devices |
| 26 24 16 | Panelboards |
| 26 27 26 | Wiring Devices |
| 26 28 13 | Fuses |
| 26 28 16 | Enclosed Switches and Circuit Breakers |
| 26 29 13.03 | Manual and Magnetic Motor Controllers |
| 26 51 19 | LED Interior Lighting |
| 26 56 19 | LED Exterior Lighting |

DIVISION 27 – COMMUNICATIONS

| <i>Section Number</i> | <i>Section Title</i> |
|-----------------------|---|
| 27 05 10 | Common Work Requirements for Telecommunications |
| 27 05 36 | Miscellaneous Pathways for Telecommunications |

| | |
|----------|---|
| 27 05 53 | Identification for Telecommunications |
| 27 08 00 | Commissioning of Telecommunications |
| 27 11 16 | Telecommunications Cabinets, Racks, Frames & Enclosures |
| 27 13 13 | Telecommunications Copper Backbone Cabling |
| 27 15 13 | Telecommunications Horizontal Cabling |

DIVISION 28 – ELECTRONIC SAFETY AND SECURITY – NOT USED

SITE AND INFRASTRUCTURE SUBGROUP

DIVISION 31 – EARTHWORK

| <i>Section Number</i> | <i>Section Title</i> | <i>Control Rev.</i> |
|-----------------------|--|---------------------|
| 31 10 00 | Site Clearing | |
| 31 20 00 | Earth Moving | |
| 31 23 00 | Trenching, Backfilling and Compacting | |
| 31 23 18.13 | Soil, Fill, Backfill, CU Structural Soil, and Construction and Demo Debris Removal | PBC 01_07/31/15 |
| 31 23 18.14 | CCDD - Clean Construction or Demolition Debris and Uncontaminated Soil Disposal | PBC 01_07/31/15 |
| 31 23 18.14A | CCDD - Uncontaminated Soil Drawing Notes | PBC 01_07/31/15 |
| 31 23 18.15 | Special, Non-Hazardous Special and Hazardous Waste Soil Removal and Disposal | 05_01/21/10 |
| 31 23 19 | Dewatering | |
| 31 23 23 | Acceptance of Backfill, Topsoil, and CU Structural Soil | PBC 01_07/31/15 |
| 31 23 33 | Trenching and Backfilling | |
| 31 25 00 | Sediment Control | |

DIVISION 32 – EXTERIOR IMPROVEMENTS

| <i>Section Number</i> | <i>Section Title</i> |
|-----------------------|----------------------|
| 32 12 16 | Asphalt Paving |
| 32 13 13 | Concrete Paving |
| 32 91 13 | Topsoil |
| 32 92 00 | Seeding and Sodding |
| 32 93 00 | Planting |

DIVISION 33 – UTILITIES

| <i>Section Number</i> | <i>Section Title</i> |
|-----------------------|-----------------------------------|
| 33 05 00 | Common Work Results for Utilities |
| 33 31 00 | Sanitary Sewerage Utilities |
| 33 41 00 | Storm Sewer Utility Drainage Pipe |

END OF TABLE OF CONTENTS

**SECTION 00 01 11
INFORMATION AVAILABLE TO BIDDERS - REPORTS**

PART 1 - GENERAL

1.1 SUMMARY

- A. This document summarizes information available to Bidders, in addition to contract documents, including:
 - 1. Geotechnical Soils report.
 - 2. Environmental Reports
 - 3. FF&E Manual
- B. Above information is available for information only. The Owner and the Architect do not guarantee the accuracy or validity of the data, nor do they assume any responsibility for the Contractor's interpretation of the data.
- C. Verify data and existing conditions. At Contractor's option, perform additional investigations at own expense.

1.2 GEOTECHNICAL REPORT

- A. The following is the geotechnical report prepared for the project site and is as follows:
 - 1. By Flood Testing Laboratories, Inc; dated July 12, 2016; titled "Geotechnical Soils Report".

The report is included in Book #4: Existing Conditions Reports.

1.3 ENVIRONMENTAL REPORTS

- A. The following are the environmental reports prepared for the project and are as follows:
 - 1. By Environmental Consulting Group, Inc; dated June 13, 2016; titled "Lead-Based Paint Inspection Report".
 - 2. By Environmental Consulting Group, Inc; dated July 14, 2016; titled "Hazardous Materials Report".
 - 3. By Environmental Consulting Group, Inc; dated July 14, 2016; titled "Asbestos Materials Testing Report".
 - 4. By Environmental Consulting Group, Inc; dated August 5, 2016; titled "Ground Penetrating Radar Survey".
 - 5. By Environmental Consulting Group, Inc; dated October 24, 2016; titled "Asbestos Materials and Lead Based Paint Testing Report".
 - 6. **By Environmental Consulting Group, Inc; dated January 15, 2018; titled "Lead-Based Paint Abatement Clarification".**

The reports are included in Book #4: Existing Conditions Reports.

1.4 FF&E MANUAL

- A. The following is the FF&E Manual prepared for the project and is as follows:

1. By STL Architects, Inc; dated December 6, 2017; titled "Furniture, Fixtures, and Equipment Manual".

1.5 RELATED REQUIREMENTS SPECIFIED ELSEWHERE

- A. Concealed Conditions: General and Supplementary Conditions.

PART 2 - PRODUCTS (NOT USED)

PART 3 - EXECUTION (NOT USED)

END OF SECTION

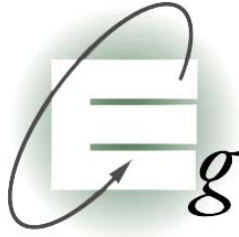

E n v i r o n m e n t a l C o n s u l t i n g G r o u p , I n c .

January 15, 2018

Ms. Beatriz Gonzalez Rajal
STL Architects
808 N. Dearborn Street
Chicago, Illinois 60610

Re: **Lead-Based Paint Abatement Clarification**
Williams Park Field House #261 – PBC Project #11320
2710 S. Dearborn Street ([2820 S State St](#))
Chicago, Illinois

Dear Ms. Rajal:

In response to the PBC request, Environmental Consulting Group, Inc. (ECG) has issued the below clarification for the lead-based paint project at the Williams Park Field House located at 2710 S. Dearborn Street in Chicago, Illinois. ([2820 S State St](#))

Since the building is scheduled for demolition, IDPH regulations for lead-based paint are not applicable to this project. The contractor shall disregard the lead-based paint abatement specification SECTION 02 83 19.13 as found in the bid specifications. Lead-based paint abatement is not required prior to demolition of this building. Environmental contractor must follow OSHA and EPA regulations for controlling lead exposures in the construction industry. Refer to the bottom of Page 1 of the Environmental Scope Sheets Section 02 24 01 for additional removal information.

Ms. Beatriz Gonzalez Rajal
January 15, 2018
Page 2

If you have any questions or comments, please contact our office.

Sincerely,

ENVIRONMENTAL CONSULTING GROUP, INC.

Mark A. Schleyer -

Mark A. Schleyer
Vice President

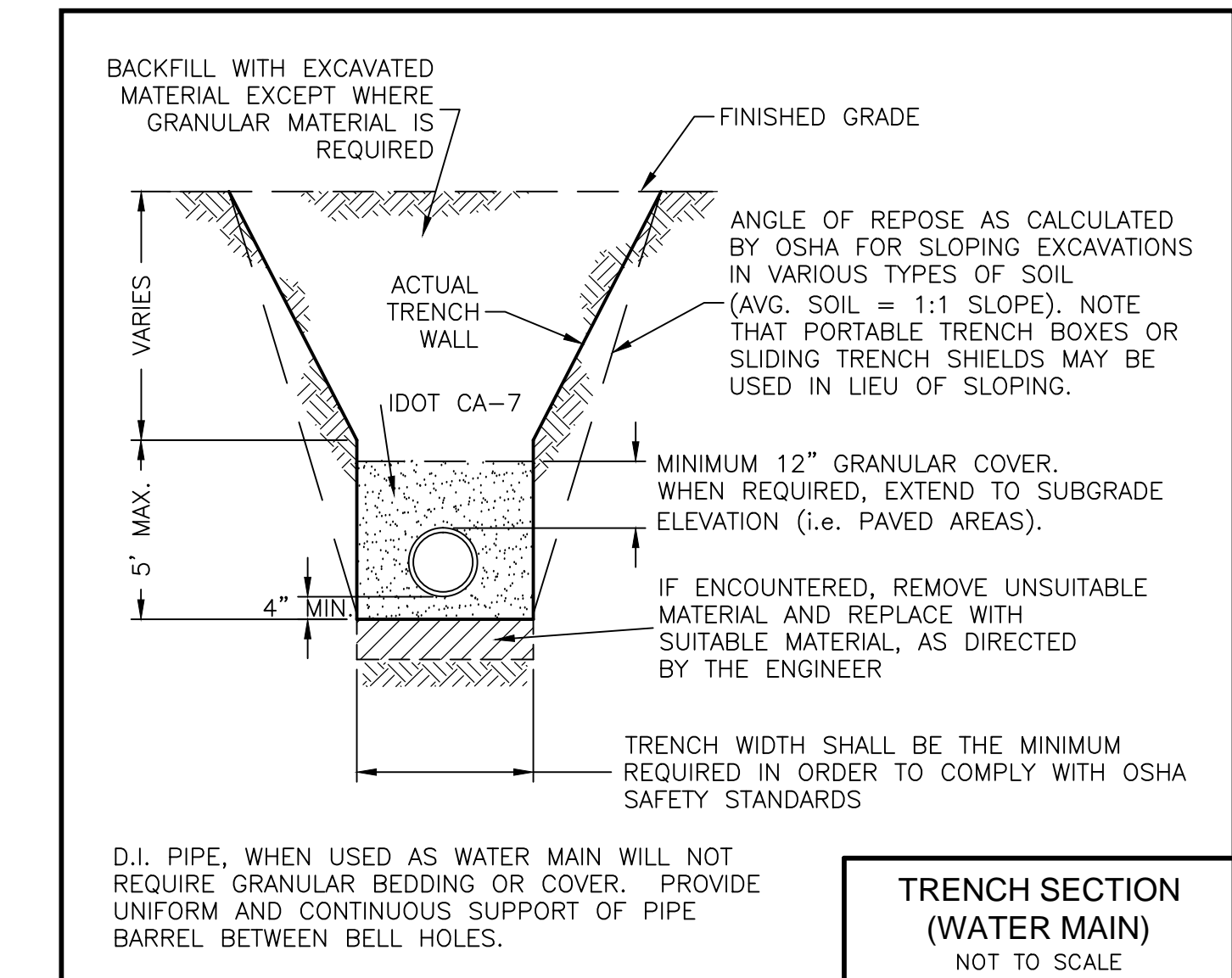
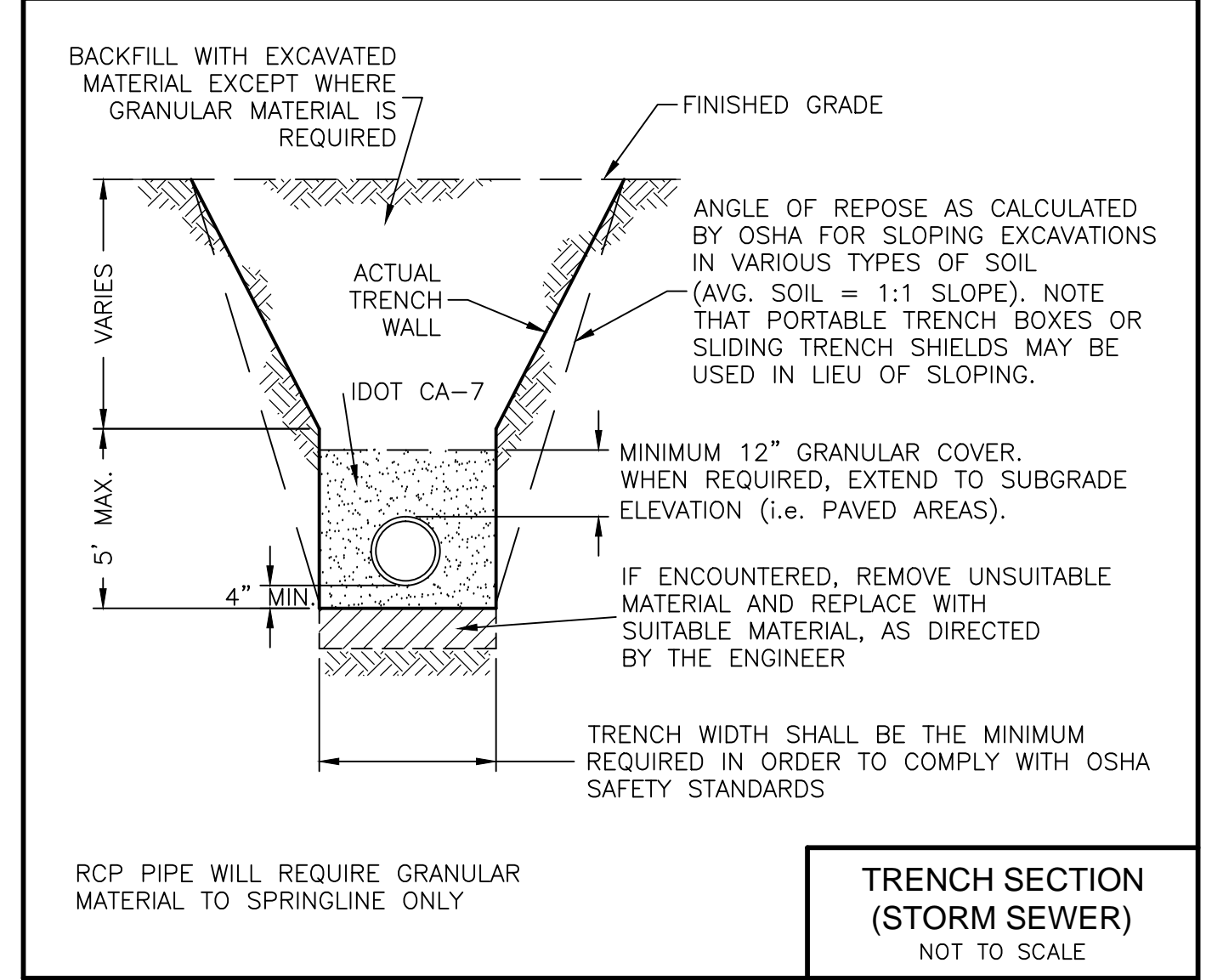
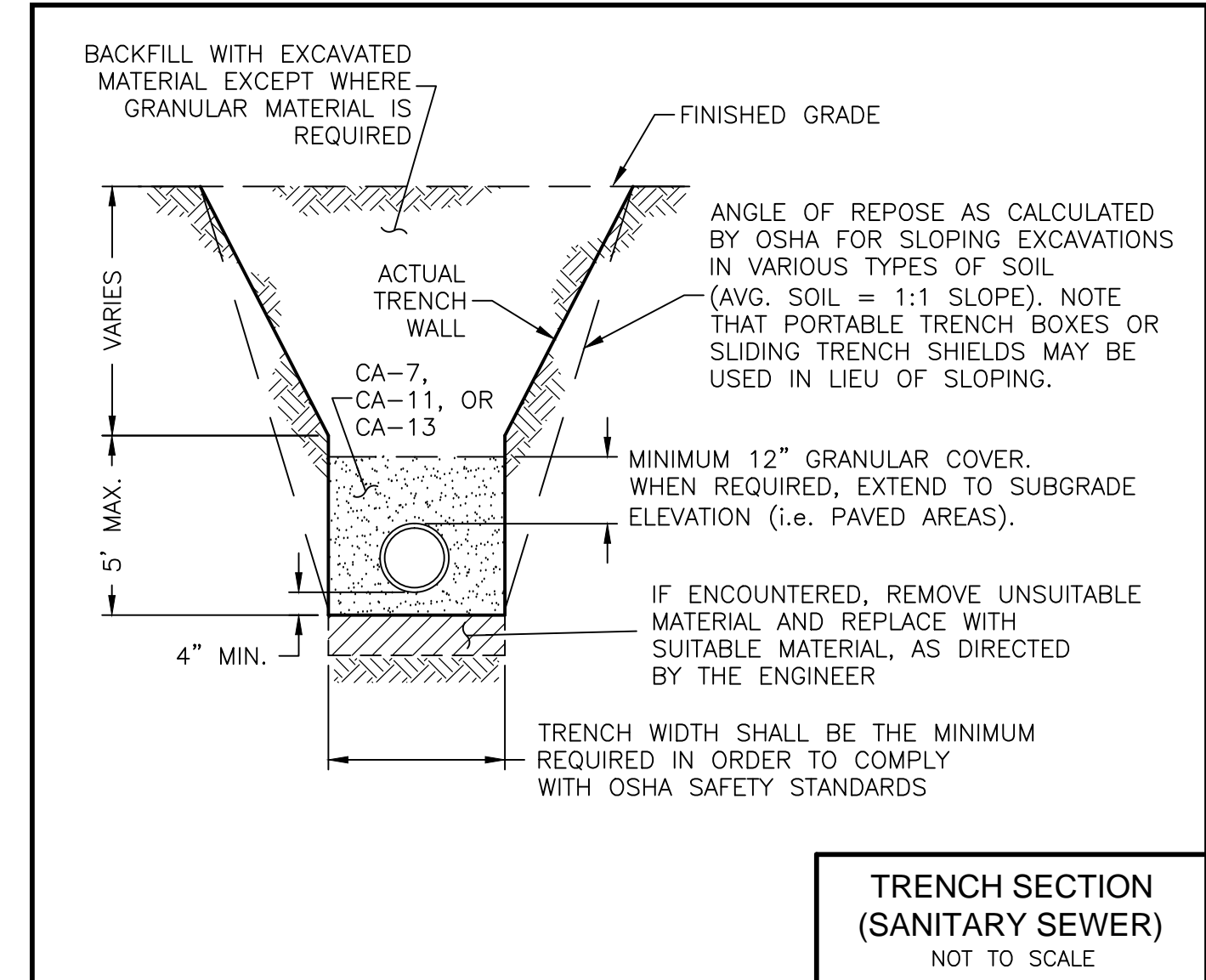
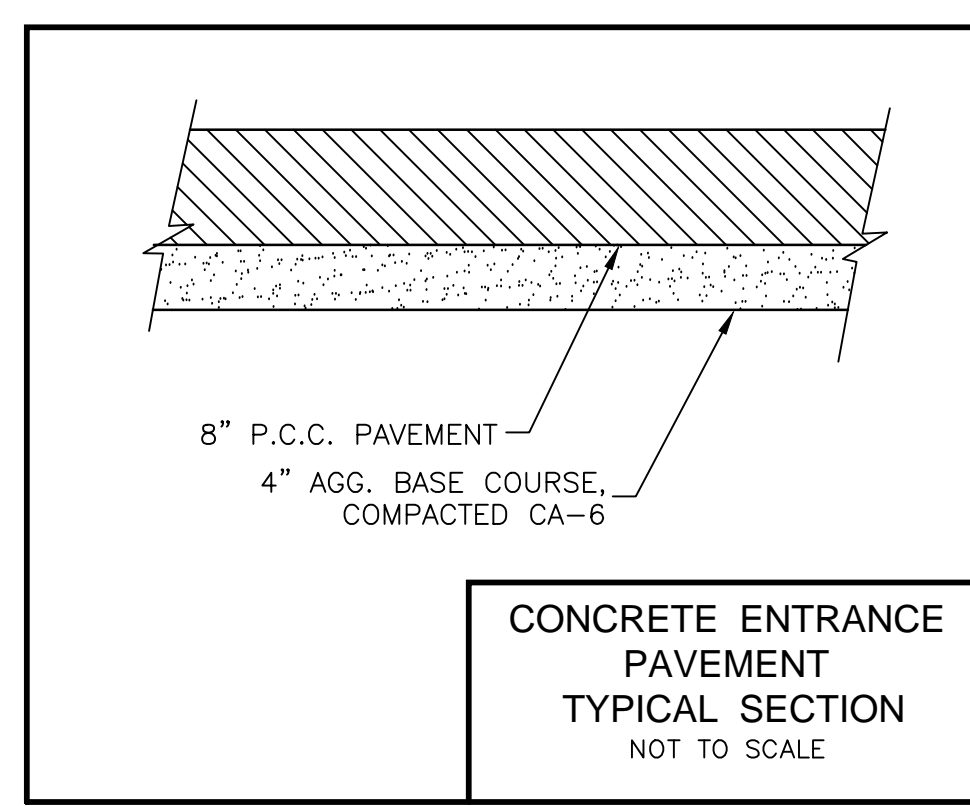
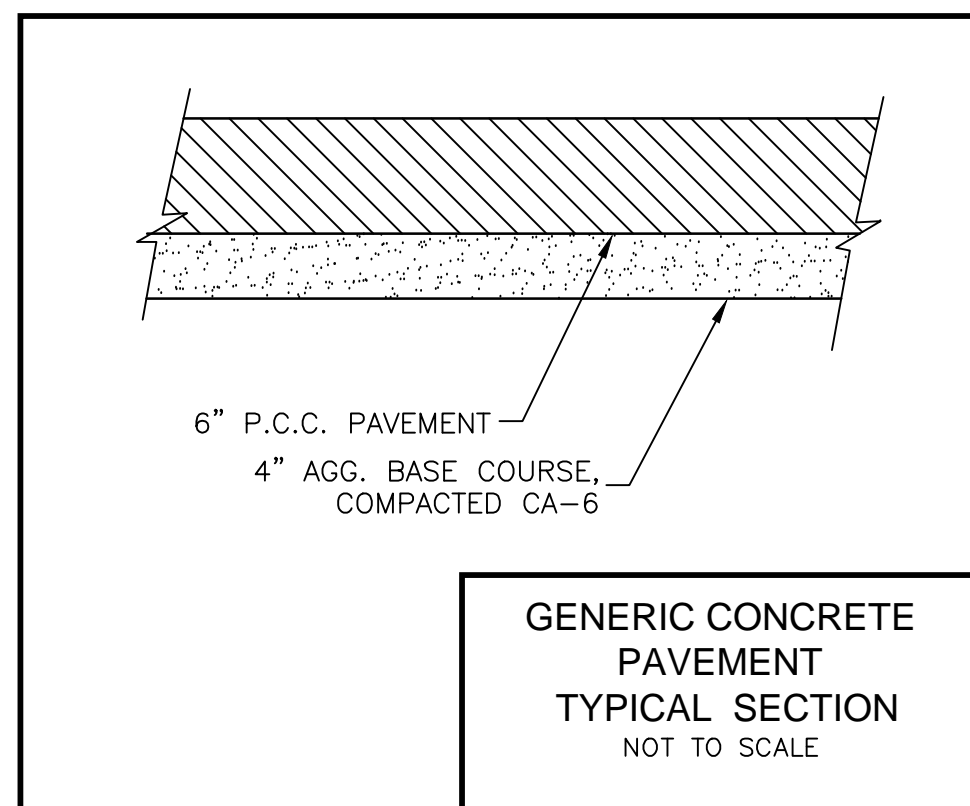
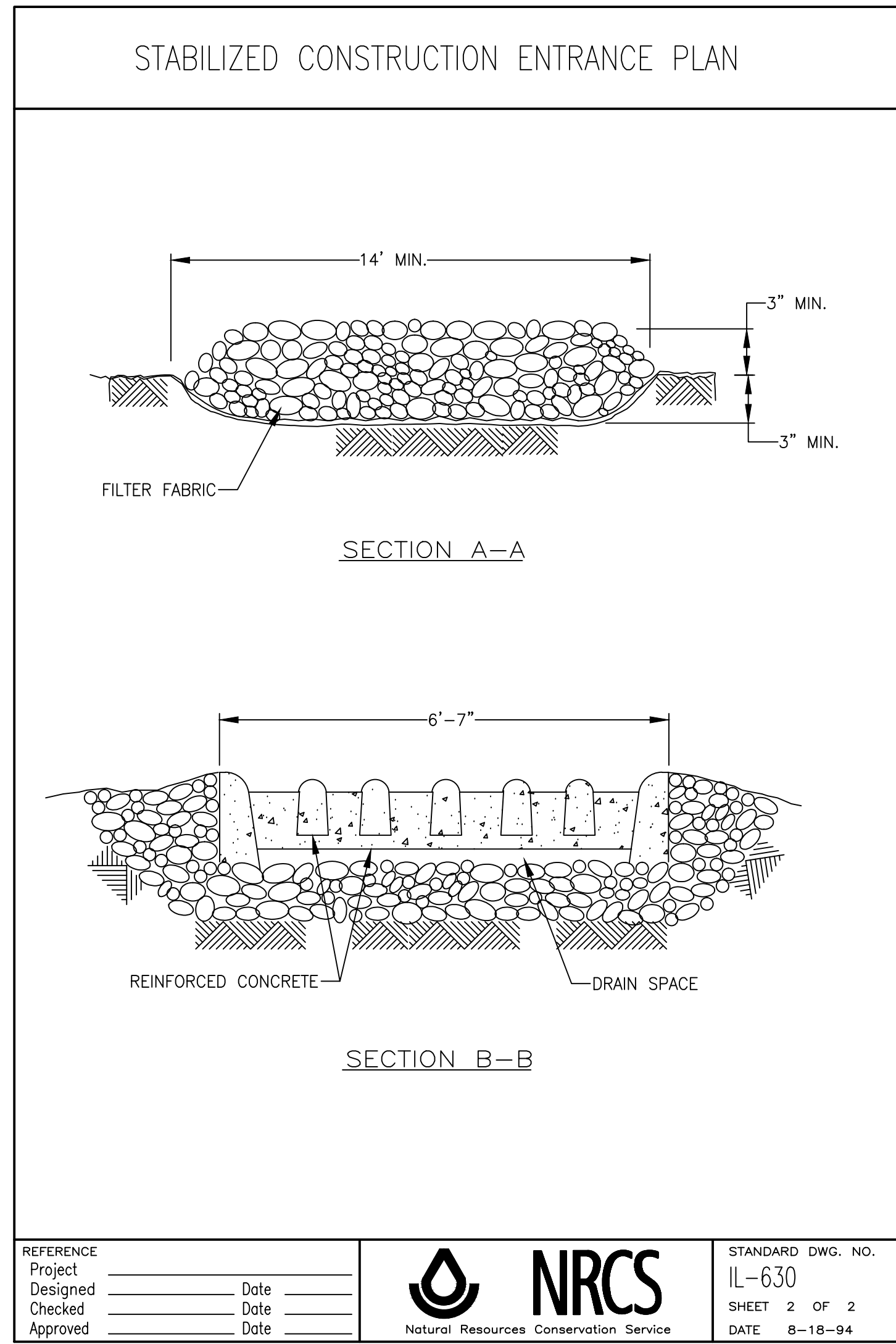
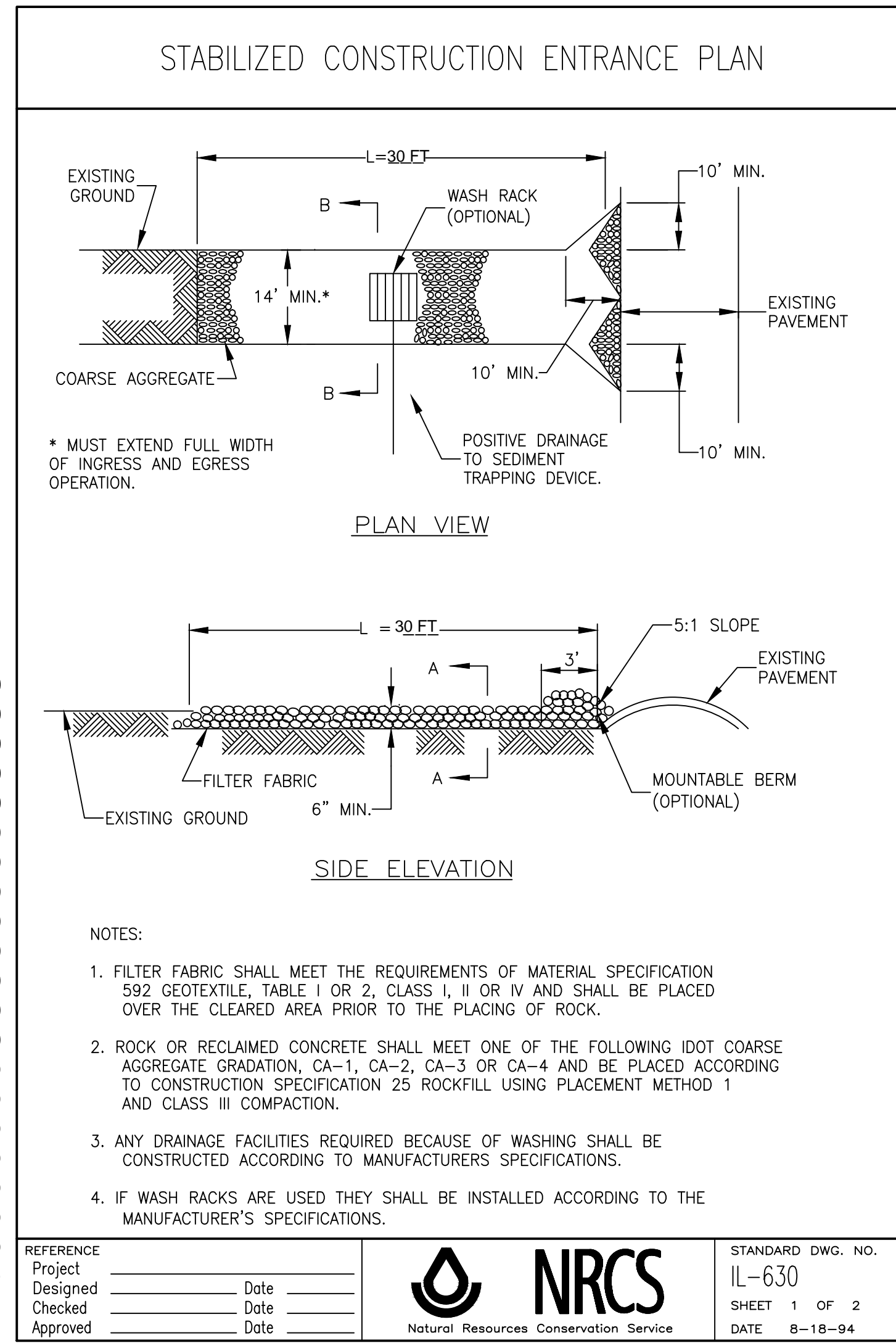
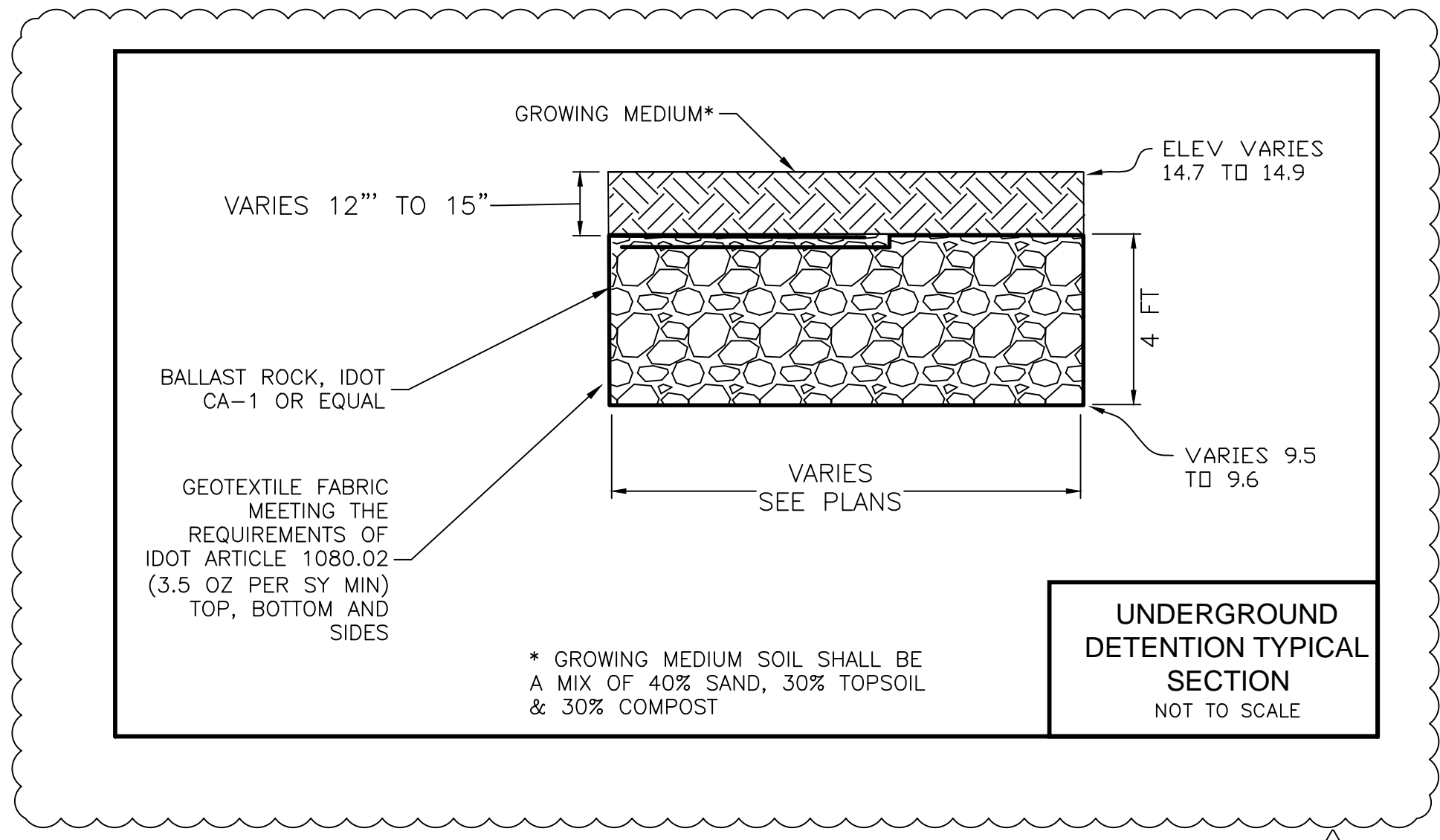
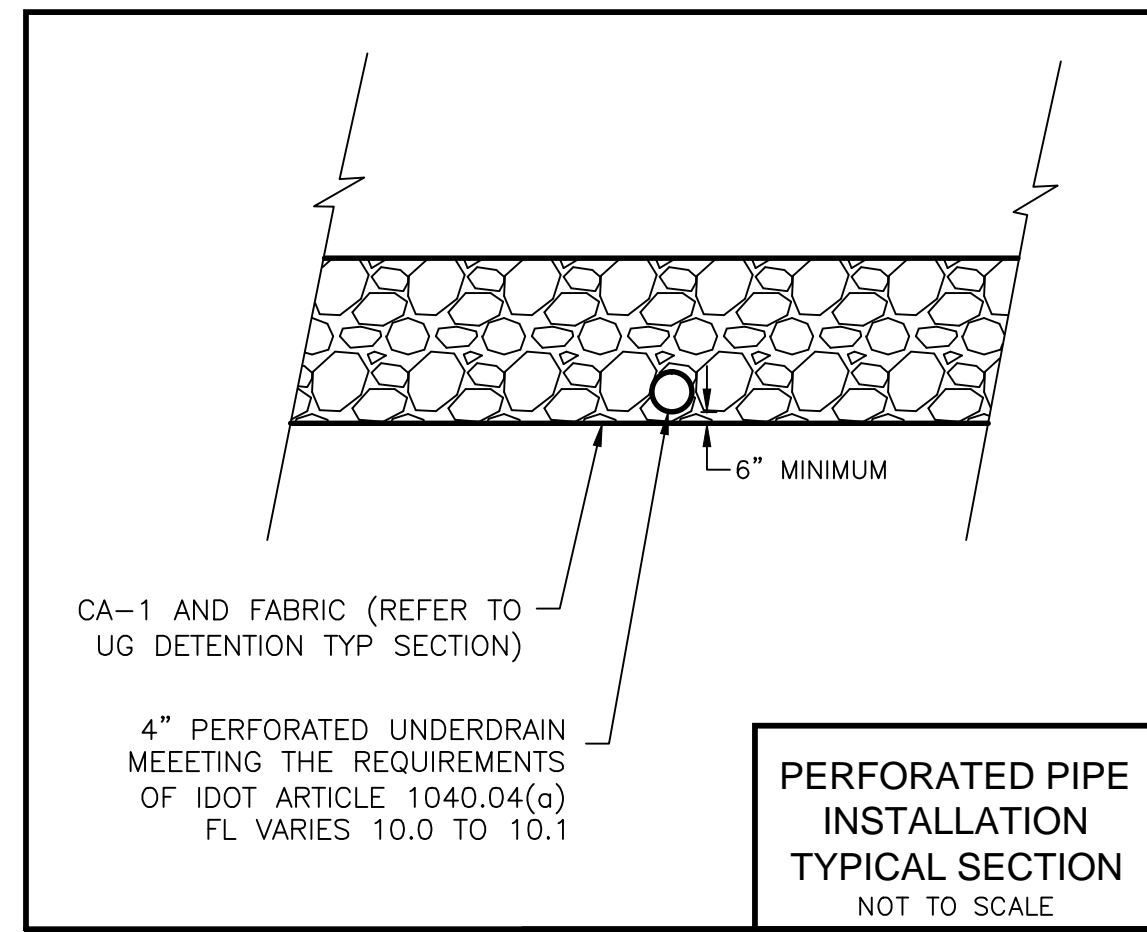
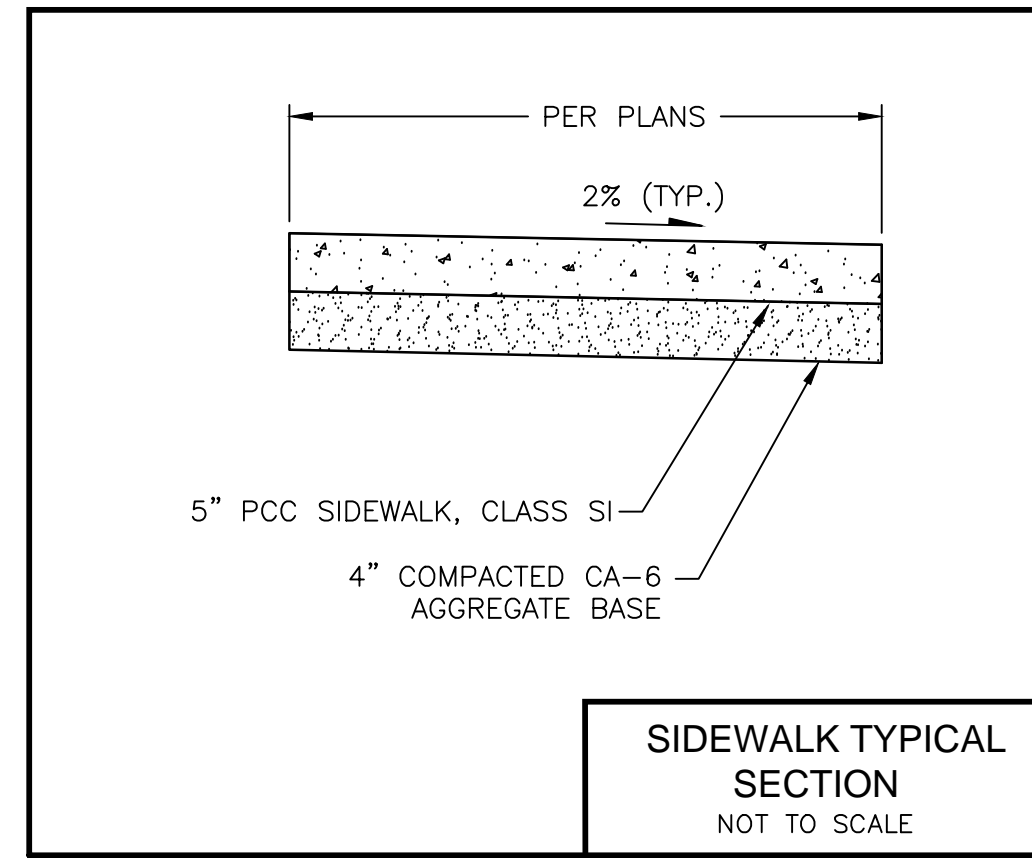

WILLIAMS PARK FIELDHOUSE
PARK #261
2820 SOUTH STATE STREET
CHICAGO, IL 60616
CHICAGO PARK DISTRICT
CITY OF CHICAGO, MAYOR RAHM ELMANN

ARCHITECT OF RECORD
STL Architects

STLARCHITECTS

808 N Dearborn Street, Chicago, Illinois 60610
T 312.644.9850 F 312.644.9846
WEB: www.stlchicago.com

Mc Bride Engineering
1820 N. Ridge Road, Suite 202 Homewood, IL 60430
Civil Engineers of Record

Daniel Weinbach & Partners
53 W. Jackson Blvd., Suite 250
Chicago, IL 60604
Landscape Architects of Record

Arup Engineering
25 East Wacker Drive, Suite 1900
Chicago, IL 60601
Structural & MEP/FP Engineers of Record

Environmental Consulting Group
155 S. York Street, Suite 250
Evanston, IL 60128
Environmental Hazardous Material Testing

Flood Testing Labs
1945 E. 87th Street, Chicago, IL 60617
Geotechnical Engineers of Record

Faithful & Gould
20 N. Upper Wacker Dr, Suite 2143
Chicago, IL 60606
Cost Estimating

| Issuance | | |
|----------|------------------------------|------------|
| Mark | Description | Date |
| 6 | Addendum #3 | 1/15/2018 |
| | Issue for Bid | 12/06/2017 |
| | Certified Permit Corrections | 8/03/2017 |
| | Permit & Bid | 6/01/2017 |

PBC Project Name: Williams Park Fieldhouse
PBC Contract No.: C1593
Project No.: 11320

Title
CONSTRUCTION DETAILS

Sheet
C1.7

C1.7 CONSTRUCTION DETAILS

M:\2016\16131\16131_WORKING.DWG 1/16/2018 11:13 AM