

BUILDING



COMMUNITY

PUBLIC BUILDING COMMISSION OF CHICAGO
5th Annual Contractor Open House

South Shore Cultural Center
7059 S. South Shore Drive

Monday, December 6, 2010
8:00 a.m.—12:00 noon



Mayor Richard M. Daley, Chairman
Erin Lavin Cabonargi, Executive Director

welcome

Greetings,

On behalf of Richard M. Daley, Chairman, and the Board of Commissioners of the Public Building Commission of Chicago (PBC), I welcome you to the PBC's fourth annual Contractor Open House, entitled "Building Community."

The purpose of this event is to allow the PBC to present you with our pending 2011 construction projects and also share additional information regarding changes we've made at the PBC to make it easier for you to do business with us.

The PBC is committed to constructing projects that improve the quality of life for all Chicago residents. We also are committed to building capacity and diversity in the construction and professional services marketplace. Each of the projects that the PBC undertakes helps to create and expand opportunities for a multitude of firms like yours that do business in the construction industry.

At this session we will be sharing with you our construction plans for the many projects that we intend to bid in the 2011 calendar year and beyond. Session attendees should be excited to learn of the great variety of 2011 PBC projects, projects that will include the construction of campus parks, libraries, schools, firehouses and police stations. To maximize the benefit to you, this year we have invited University of Chicago, Metropolitan Water Reclamation District of Greater Chicago and City of Chicago to share their capital programs in addition to those the Public Building Commission is responsible for.

Chicago is truly a dynamic place to live, work and play. The city is changing everyday for the better. The type of change the PBC institutes is beneficial because it provides new and enhanced opportunities for city services. We need qualified construction contractors that are ready and able to perform if we are to be successful in 2011 and beyond.

I urge you to ask questions throughout the course of the session to enhance your understanding of the capital projects in development by the PBC. I also urge you to network with your fellow attendees and exhibitors. By creating these new relationships, you will enhance your collective abilities to bid and win PBC work.

I wish you good luck and much success as you seek to sustain and grow your businesses. We appreciate your participation in this event and look forward to working together in "Building Community."

Warmest Regards,



Erin Lavin Cabonargi, Executive Director

8:00 a.m.-9:00 a.m.: Registration

9:00 a.m.-10:00 a.m.:

TIF Works and University of Chicago Research Center (Room C)

Professional Services Opportunities (Room A)

Assist Agencies for General Contractors and Subcontractors (Room B)

10:00 a.m.-11:00 a.m.: General Session (Room C)

- **Erin Lavin Cabonargi, Executive Director**
 - Welcome
 - Introduction
 - Program Overview
 - Program Statistics
 - 2010 & 2011 Project Completions
 - Upcoming Opportunities
 - Environmental Sustainability
 - Economic Sustainability

- **PBC Contract Provisions that Benefit You:
Paul Spieles, Chief Operating Officer**
 - Ongoing Initiatives
 - Economic Sustainability Provisions
 - Local Subcontracting Requirements
 - Local Hiring Provisions
 - New Invoicing Protocol (CW) &
New Document Controls Procedures

- **Procurement:
Rusty Castillo, Deputy Director of Procurement**
 - How to Do Business with the PBC
 - Pre-Qualifications

- **Compliance:
Charles Kelly, Deputy Director of Administration**
 - MBE/WBE Participation
 - LCP Tracker, B2GNOW
 - Regular Outreach Meetings

- Question and Answer

11:00 a.m.-12:00 noon: Networking Sessions (Room A)

agenda

PBC procurement

Sign up for PBC Alerts online at www.pbcchicago.com

FINDING BID OPPORTUNITIES

The PBC issues all procurement opportunities online under PBC Alerts, sign up at www.pbcchicago.com.

PRE-BID MEETINGS

Pre-bid meetings are an excellent opportunity for sub-contractors to meet the General Contractors who are bidding on a project. The website will let you know the details about bidding opportunities, including the time and location of any pre-bid meetings.

PRE-QUALIFICATION PROCESS

The PBC will evaluate qualifications based on information provided in the "Statement of Qualifications and Financial Condition," including required attachments and performance references. Firms deemed eligible for pre-qualification will be placed on the appropriate notification list for specific projects. Notices will be sent to pre-qualified firms when the project opportunities arise. All firms are required to have a City of Chicago and General Contractors license and all other required licenses for the type of work under consideration.

PBC CLIENT AGENCIES

- City of Chicago
- Chicago Fire Department
- Chicago Police Department
- Chicago Public Library
- Office of Emergency Management & Communications
- City Colleges of Chicago
- Chicago Public Schools
- Chicago Park District
- Chicago Housing Authority
- Chicago Transit Authority

Commitment to Economic Sustainability Programs for the Community

Current procurements and resultant contracts have 6 robust economic sustainability provisions:

- Bid incentives for the employment of minority and female workers
- Bid incentives for the employment of apprentices
- Contract provisions that require at least 50% of the labor force be local residents
- Contract provisions that require community hiring, helping to employ those closest to the work at hand
- Contract provisions that require minority- and women-owned business participation
- Contract provisions for local business participation

**economic
sustainability**

CHICAGO PUBLIC SCHOOLS

Air Force Academy Renovation (Phase II)

Tentative Bid Date: January 2011

This project converts the former Abbott Elementary School into a military high school. The scope of work includes ADA accessibility upgrades (elevator, stage lift, exterior ramps, and full toilet room renovations), warming kitchen renovation, two science labs, locker rooms, interior finish repairs, lighting replacement and retrofit, roof replacement, exterior window replacement, asbestos abatement, and landscape upgrades.

Back of the Yards High School (Vertical Construction)

Tentative Bid Date: January 2011

This project will implement the CPS Urban Model High School (UMHS) prototypical design to serve 1,200 students. This 200,000 SF, three-floors plus lower level, steel frame and masonry construction building will include music, art, and athletic functions.

Collins High School Renovation

Tentative Bid Date: January 2011

Scope includes conversion of an auto shop into a library/media center and post-secondary education spaces, interior classroom finishes throughout the Arts Building, new lighting and sound system for the auditorium, new filtration system for swimming pool and landscape at both main entry plazas.

Edgebrook Elementary School Addition

Tentative Bid Date: April 2011

Scope of this project is an addition to the existing school, containing 8 classrooms, a warming kitchen and lunchroom, a science classroom, restrooms, storage and circulation.

CHICAGO PUBLIC LIBRARIES

Edgewater Branch Library

Tentative Bid Date: November 2011

Based on a new Prototype "C" design, this new 18,665 SF, two-story full service branch library will replace the existing Edgewater Branch Library at the same location.

CHICAGO FIRE DEPARTMENT

Engine Company 16

Tentative Bid Date: January 2011

This new 19,725 SF fire house will be constructed on the city-owned property at 3901 South Wabash Avenue. It will be a modified Prototype 'B' engine company with a Hazmat Unit, and include the following components: a large apparatus bay to house multiple emergency vehicles, full kitchen, locker rooms, toilet facilities, sleeping quarters, officers quarters, physical training room, meeting room, education room, EMS Field Division South offices, a 150' communication tower, and parking for approximately 30 vehicles.



CHICAGO PARK DISTRICT

Gateway Harbor

Tentative Bid Date: March 2011

Located at Dime Pier at the mouth of the Chicago River just south of Navy Pier. The scope includes encapsulating Dime Pier; building approximately 235 boat slips; new finger docks on the south side of Navy Pier for commercial vessel use; installation of approximately one acre of land fill to build a harbor facility.



**2011 schedule
for construction**

CHICAGO PUBLIC SCHOOLS

<u>PROJECT NAME</u>	<u>TENTATIVE BID DATE</u>
Air Force Academy Renovation (Phase II)	January 2011
Back of the Yards High School (Vertical Construction)	January 2011
Collins High School Renovation	January 2011
Edgebrook Elementary School Addition	April 2011

CHICAGO PUBLIC LIBRARIES

<u>PROJECT NAME</u>	<u>TENTATIVE BID DATE</u>
Edgewater Branch Library	November 2011

CHICAGO FIRE DEPARTMENT

<u>PROJECT NAME</u>	<u>TENTATIVE BID DATE</u>
Engine Company 16	January 2011

CHICAGO PARK DISTRICT

<u>PROJECT NAME</u>	<u>TENTATIVE BID DATE</u>
Gateway Harbor	March 2011

**2011 schedule
for construction**

assistance agencies

The agencies listed below are available to offer bidders assistance in connection with identifying certified minority- and women-owned businesses.

Association of Asian Construction Enterprises
5500 Touhy Ave., Unit K, Skokie, IL, 60062
Attn: Perry Nakachi
Tel: (847) 673-7377

Black Contractors United
400 W. 76th St., Chicago, IL 60620
Attn: Florence Cox
Tel: (773) 483-4000 Fax: (773) 482-4150
bcunewera@ameritech.net

Chicago Minority Supplier
Development Council
105 W. Adams, #2300, Chicago IL 60603
Attn: Sheila Hill
Tel: (312) 755-8880 Fax: (312) 755-8890
shill@cmbsc.org

City of Chicago Department of
Procurement Services
121 N. LaSalle St., Room 604, Chicago, IL 6060
Attn: Jamie Rhee
Tel: (312) 744-9750
jamie.rhee@cityofchicago.org

Cook County Government
Office of Contract Compliance
118 N. Clark St., Chicago, IL 60602
Attn: Betty Hancock
Tel: (312) 603-5502 Fax: (312) 603-4547
bhperry@cookcountygov.com

Cosmopolitan Chamber of Commerce
203 N. Wabash Ave., Chicago IL 60601
Attn: Carnice Carey
Tel: (312) 499-0611 Fax: (312) 701-0095
ccarey@cosmococ.org

Department of Community Development
121 N. LaSalle, Rm. 1000
Chicago, IL 60602
Attn: Chris Raguso
Tel: (312) 744-4190

Federation of Women Contractors
5650 S. Archer Ave., Chicago, IL 60638
Attn: Beth Dorja
Tel: (312) 360-1122 Fax: (312) 360-0239
fwcchicago@aol.com

Hispanic American Construction Industry Association
901 W. Jackson Blvd., Ste. 205, Chicago, IL 60607
Attn: Paul Cerpa
Tel: (312) 666-5910 Fax: (312) 666-5692
pcerpa@haciaworks.com

Illinois Hispanic Chamber of Commerce
855 W. Adams, Suite 100, Chicago, IL 60607
Attn: Omar Duque
Tel: (312) 425-9500

Latin American Chamber of Commerce
3512 W. Fullerton Ave., Chicago, IL 60647
Attn: Elio Montenegro
Tel: (773) 252-5211 Fax: (773) 252-7065
emontenegro@latinamericanchamberofcommerce.com

National Association of Women Business Owners
Chicago Area Chapter
230 E. Ohio, Suite 400, Chicago, IL 60611
Attn: Sheila Gidley
Tel: (312) 224-2605 Fax: (312) 644-8557
info@nawbochicago.org

State of Illinois
Central Management Services
100 W. Randolph St., Ste. 4-400 Chicago, IL 60602
Attn: Harry Reinhard
Tel: (312) 814-5539

Women's Business Development Center
8 S. Michigan Ave., Ste 400, Chicago, IL 60603
Attn: Hedy Ratner
Tel: (312) 853-3477 Fax: (312) 853-0145
hratner@wbdc.org

Public Building Commission of Chicago Contacts

Purchasing

Rosalinda "Rusty" Castillo, Deputy Director of Procurement 742-0121

Community Relations

Dwayne Hightower, Deputy Director for Community Relations 744-8278

Construction Employment and Minority Business Affairs

Chuck Kelly Deputy Director of Administration 744-9679

Senior Contract Officer

Janice Meeks Construction 744-7240

Gary Bell Professional Services 744-9287

Recognizing the need for professional management of public construction projects, Mayor Richard J. Daley in 1956 formed the Public Building Commission of Chicago to develop quality government facilities, an important goal that continues to be at the heart of the organization. Today, PBC chairman Mayor Richard M. Daley is joined by 10 other Chicago business and civic leaders whose dedication to the city and its communities has led them to volunteer their time.

PBC clients include the City of Chicago, Cook County, the Chicago Public Library, the Chicago Public Schools, the Chicago Park District and the City Colleges of Chicago. The PBC professional staff manages each project through planning, design and construction, functioning as an important link between clients and contractors.

The PBC's first major construction project was the Chicago Civic Center, which continues to be its headquarters. Started in 1963 and opened in 1966, it was re-dedicated the Richard J. Daley Center in 1976 to honor the late mayor shortly after his death. Heralded around the country as an architectural gem, the open, modern design of the Daley Center revolutionized government structures in Chicago and throughout the nation.

A year after the Civic Center was completed, the City of Chicago commissioned Pablo Picasso to create a steel sculpture to grace the facility's grand plaza. This work of art helped establish the Daley Center as one of Chicago's most important architectural landmarks and has become a distinctive symbol of the city itself.

about the PBC

thanks

SPECIAL THANKS

Public Building Commission of Chicago

Mayor Richard M. Daley, Chairman

Bishop Arthur M. Brazier

Adela Cepeda

Dr. Robert B. Donaldson II

Benjamin Reyes

Mary B. Richardson-Lowry

Cynthia M. Santos

Samuel Wm. Sax

Todd H. Stroger

Gerald M. Sullivan

Bryan Traubert

EXHIBITORS

Chicago Park District

Chicago Public Schools

Chicago Women in Trades

City of Chicago, Department of Community Development

City of Chicago, Department of Procurement Services

Coalition for United Community Action

Dawson Skill Center

Federation of Women Contractors

Illinois Hispanic Chamber of Commerce

Hispanic American Construction Industry Association

Metropolitan Water Reclamation District of Greater Chicago

New Skill Builders

State of Illinois Capital Development Board

University of Chicago

Women's Business Development Center

PROGRAMS

Registration: 8:00 a.m.-9:00 a.m.

General Contractor & Professional Services Sessions: 9:00 a.m.-10:00 a.m.

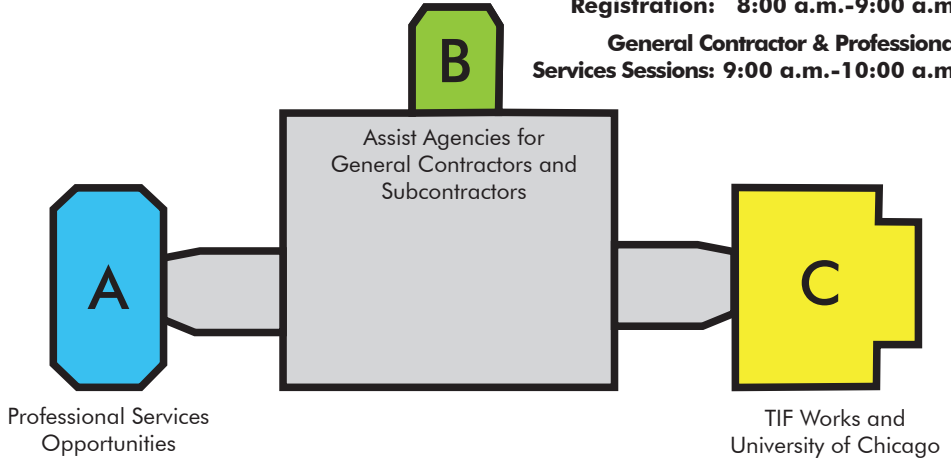

General Session: 10:00 a.m.-11:00 a.m.

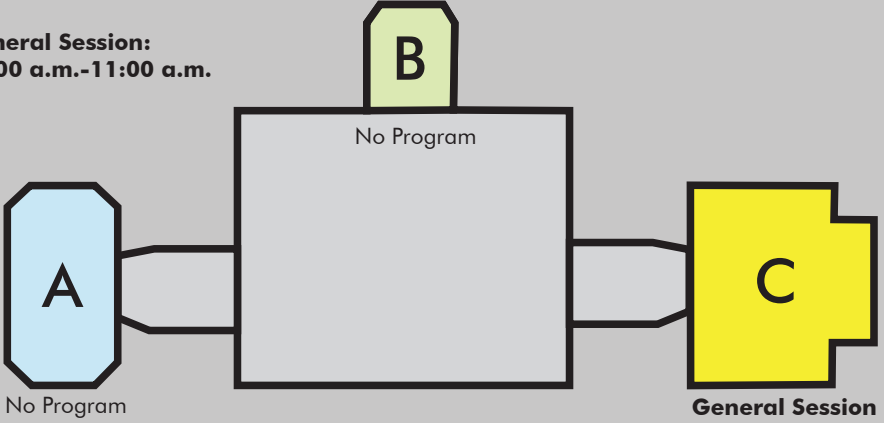

Networking Session: 11:00 a.m.-12:00 noon

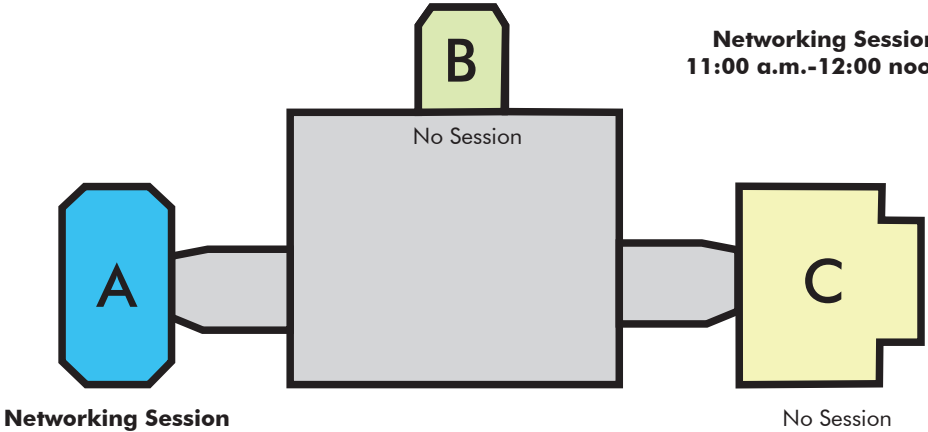

PUBLIC BUILDING COMMISSION OF CHICAGO

50 W. Washington St. Rm. 200

Chicago, IL 60602

Tel: 312-744-3090 Fax: 312-744-8005

www.pbcchicago.com

